

Request No.	Date	Part of Tender	Requests/Recommendations	Answer
1	24.05.	TV	What is the native code and bit rate of the set up?	The recording codec requirements are to be found in section C.2.12
2	24.05.	TV	Is there only one channel playback required?	Yes there is only one channel playback from the video server
3	24.05.	TV	What about backup plan for video server play back?	There is no back up channel for the video server
4	24.05.	TV	There is no mention of NLE solution?	Yes, it's not required.
5	24.05.	TV	How many MAM server clients will be required (browsing and user)?	One client is required in the tender, this is to be implemented on the configuration PC. The provided licence should up to 5 clients.
6	24.05.	TV	Give detail of bosch audio intercom and audio control mixer system required?	Details of the Bosch intercom system will be provided. However there is no audio mixing console foreseen in the system.
7	24.05.	TV	How will you control the audio flow which needs to be embedded with the relevant (without audio console)?	The audio levels can be trimmed using the configuration software tool for the embedders. (E.g. "Dashboard" software if Ross cards are used)
8	24.05.	TV	How much play out clients?	One client is required in the tender, this is to be implemented on the configuration PC.

Request No.	Date	Part of Tender	Requests/Recommendations	Answer
9	24.05.	TV	How many ingest clients?	One client is required in the tender, this is to be implemented on the configuration PC.
10	24.05.	TV	How many work stations are required, for play out graphics, scheduling, planning, admin, browsing etc?	The graphics system has its own display and keyboard. The other functions such as scheduling, planning, admin, browsing will be implemented on the configuration PC.
11	24.05.	TV	What is the safety standard that should be followed according to the Zambian regulations?	To be advised at award
12	24.05.	TV	What work permit should be obtained?	To be advised at award
13	24.05.	TV	Will the press galley be turned entirely into the control room?	No. The size of the new control room will be as defined in the tender.
14	24.05.	TV	You are only asking for 5 cameras shouldn't you consider having more cameras in the chamber in order to pick the next speaker on the floor/	Only 5 cameras have been requested
15	24.05.	TV	Do you consider having a dual master reference incase of power loose?	Only one master reference generator has been requested
16	24.05.	TV	Are you considering alternatives of the equipments to be supplied?	Yes, but each alternative must fulfill the requirements as defined by the tender. The technical specifications must be submitted together as part of the bid.

Request No.	Date	Part of Tender	Requests/Recommendations	Answer
17	24.05.	TV	The length in the control room is 7m. Is it possible to have its longer to accommodate for a small room where equipment and separate colling can be installed?	The rack with the noisy units will be housed in the small technical room beside the elevator. See position which attached (No 05) Diagram of cable lengths.
18	24.05.	TV	They are pictures for the Panasonic are they just examples or that the preferred brand?	See terms and conditions for tendering.
19	24.05.	TV	Is the bidder suppose to choose the colour for the cameras or the client has a prefers?	This is described in the TV- concept. The cameras in chamber have to be black/dark grey and in committee rooms are in white colour.
20	24.05.	TV	What is the height of the brackets?	This task will be part of execution phase by the integrator.
21	24.05.	TV	Will the interface be physical or should it be international standard?	See tender document.
22	24.05.	TV	Should it be bit rate of the system or the codec?	See answer to request to item 1.
23	24.05.	TV	They is no provision for the resolution in the bid document?	Overall resolution of the cameras must be approx. 1000 TV-Lines. The base band video standard within NAZ is 1080i50.
24	24.05.	TV	Is there pre-seats for the MPS which are permanent?	The floorplan with seating layout will be attached. See attachment (No 07).

Request No.	Date	Part of Tender	Requests/Recommendations	Answer
25	24.05.	Radio	Do you have audio processor or it's direct from the transmitter?	It will be come direct from the transmitter.
26	24.05.	Radio	The shelter should it be a brick building or container?	It's up to the bidder to provide an appropriate Transmitter shelter which meets the space and safety specifications. Both solutions are acceptable. See attached example of brick building (No 01,03)
27	24.05.	Radio	Could you provide photographs for one (1) typical FM site?	Yes, as attached
28	24.05.	Radio	Is there a specific requirement from the ZICTA for brand of the equipment, or are they specific brands already approved?	There is a need for ZICTA Type approval certificate for the Brand of transmitter that the bidder intends to supply. The type approval certificate must be submitted together as part of the bid.
29	24.05.	Radio	Is there power already at the sites for the FM or it will be provided?	Power will be provided by the client.
30	24.05.	Radio	Will you need inverters or power batteries for back up?	See Bid- document, Appendix 6.
31	24.05.	Radio	Don't you think there is need to change the numbers of antennas looking at the distance of the sites?	The number of antennas must be as per the BoQ.

Request No.	Date	Part of Tender	Requests/Recommendations	Answer
32	24.05.	TV	Is there provision of the air condition in the control room for the purpose of the equipment being procured?	See answer to request to item 17. No additional air conditioning is required.
33	24.05.	Radio	How will be transportation of the signal be done is it the client or the bidder?	The signal will be received via satellite.
34	24.05.	TV	The room for housing the announcers desk with camera needs acoustic treatments.	This is nice to have feature. The bidders are invited to provide a special lump sum.
35	24.05.	TV	The session at announcer desk will be recorded offline.	Yes
36	24.05.	TV	If the ENG camera to be wanted for live production there is a need of an InterCom link between the operator in the TV control room and the person behind the camera.	See Tender document, page 169, C.5
37	24.05.	TV	Additional wallbox for OB-Van is wanted by NAZ..	This is an additional feature and will be requested by the client. See extra BoQ of TV studio. Attached (No 11).
38	24.05.	TV/ Radio	Could the date of submission be extended?	Yes, submission has been extended to 30th June 2016.
39	24.05.	TV/ Radio	Who will be responsible for the security of goods once delivered?	National Assembly of Zambia will only be responsible for goods that are delivered and officially handed over.

Request No.	Date	Part of Tender	Requests/Recommendations	Answer
40	24.05.	TV	What standard of Fibre Cable, LAN and Power connectors?	<p>LAN: CAT6/6a cable with RJ45 connectors.</p> <p>Fibre: See manufacturer's requirements and specifications for the network trunk, and video extenders.</p> <p>Power: Power cabling generally to conform to IEE 17th wiring regulations. Equipment which is part of the fixed installation in racks and desks should use "IEC" connects with corresponding distribution strips. Otherwise for other applications (lighting, wall-mounted cameras etc.) BS 1363/BS546 connectors are to be used.</p> <p>Cables installed in ducts between buildings: Rodent resistant low smoke zero halogen (LSZH) type. Suitable for outdoor use.</p> <p>Cables installed in ducts inside buildings: low smoke zero halogen (LSZH) type.</p>
41	27.05.	Radio	With reference to Appendix 6, Technical Compliance Table for Radio Expansion, 1.4,1.4.1. From experience, Rated minimum output power should be 3kW to drive a 1kW transmitter with PIE equipment, safely 5kW.	Indeed the 2.2kVA indicated is minimum dynamic power. Startup current for transmitter is very high. 3kW (rms) output rating is acceptable minimum. In order to have uniform offers from all bidders 5kW should be offered

Request No.	Date	Part of Tender	Requests/Recommendations	Answer
42	27.05.	Radio	With reference to Appendix 6, Technical Compliance Table for Radio Expansion, 1.5. From experience, Rated minimum output power should be 3kW, safely 4kW.	For Inverter/Charger, 3kW (rms) output rating should be offered.
43	27.05.	Radio	Is it not expected that the transmitter shelter will be enclosed in some kind of fencing?	The transmitter shelter must be enclosed in a wire fence with minimum dimensions of 10mx10m with lockable gate. Cyclone wire or Savanna wire are acceptable basic security fencing. The area inside the fence must be leveled and covered with 100mm layer of 10mm or 20mm crushed stone aggregates.
44	27.05.	TV	In Lot 1 (TV Studio) What is the number of SDI outputs/inputs for each wallbox, especially those meant for use by other broadcasters during major events?	See compliance tables in the tender document.
45	27.05.	TV	Isn't there need for a production audio intercom? This is envisaged to be used by the production crew especially between control Room and the Continuity studio as well as committee rooms.	See answer to request No 36.
46	27.05.	TV	Refer to ITB section 16.2 (d) – is there a specific format in which client wants the written confirmation accepting responsibility for integration?	A written confirmation in form of a letter on company letter head and signed by authorised attorney.
47	27.05.	TV	Can client provide standards for SHE requirement for both lots?	Question not very clear.

Request No.	Date	Part of Tender	Requests/Recommendations	Answer
48	27.05.	TV	Ceiling voids – check to see if there are existing runs for cable containment along with clear access into the void/s as required? Ceiling types – are these all suspended?	see (No 05) Diagram of cable lengths. In Committee Rooms there are suspended ceiling.
49	27.05.	TV	Floor to ceiling roof height – does work there require the use of scaffolding at any point?	For the position of cameras in Chamber assume max. 6m height.
50	27.05.	TV	Drops from the void to each room. Check to see that there is clearance per area to install surface mounted 'trunking' (typically 40x40mm) to the positions where the wall-boxes are anticipated. Clarify route/s as required into the control room and positioning for technical furniture.	see (No 05) Diagram of cable lengths.
51	27.05.	TV	External 'pull-boxes' and manholes for fibre-optic cables (between buildings) – check for internal/clearance and bend radii of the routes as required.	Please see attachment (No 05).
52	27.05.	TV	The requirement for upgrading the lighting in the chamber seems unclear – whose responsibility is this? If so – what lighting fixtures are already installed?	This work will be undertaken by the client.
53	27.05.	TV	The power distribution board seems to have 'old style 'Heinemann' circuit breakers. The brief mentions 'fuses' – please clarify?	This work will be undertaken by the client.
54	27.05.	TV	What power connector systems are required inside the racks? IEC, 13A, 16A?	Within the racks it would be convenient to use "IEC" variety of connects due to their size compared with BS 1363 / BS-546

Request No.	Date	Part of Tender	Requests/Recommendations	Answer
55	27.05.	TV	PIE systems for each site – is basic audio monitoring a requirement, or is no PIE necessary?	PIE is not necessary.
56	27.05.	TV	Please clarify the word 'Sambian' style power connector for mains? (Appendix 4 – presumably this should be Zambian style outlets which are either 13A (square pin) or 16A (round pin))	See answer to request no 54.
57	27.05.	TV	Will client provide distances between required equipment installations with required cable route?	Please see attachment (No 05)
58	27.05.	TV	Confirm Model number(s) of the Bosch Conference equipment in the Gallery?	DCN CCU
59	27.05.	TV	Based on previous legislature installations in South Africa, we have used Panasonic Mixers/switchers as a more cost effective solution. Please confirm that a AV-HS 450 20-input mixer would be acceptable?	See compliance tables in the tender document.
60	27.05.	TV	Blackmagic Router plus Opengear Frame solution instead of a Ross.	See compliance tables in the tender document.
61	27.05.	Radio	What power connector systems are required inside the racks? IEC, 13A, 16A? British	See answer to request no 40.
62	27.05.	Radio	PIE systems for each site – is basic audio monitoring a requirement, or is no PIE necessary?	No audio monitoring necessary.
63	27.05.	Radio	Are brick-built buildings the only consideration for the TX shelters?	See answer to request no 26.

Request No.	Date	Part of Tender	Requests/Recommendations	Answer
64	27.05.	Radio	No photos are provided for the masts/buildings as on site already to indicate location?	Please see attachment (No 01,02,03)
65	27.05.	Radio	Will 7/16DIN be acceptable as an alternative to 7/8" EIA?	7/8" is recommended. Depends on compatibility with the output connectors on the transmitter output and the power divider on the antenna.
66	27.05.	TV	Please provide the Appendix 5 and 7 "TV Technical Compliance matrix" and "TV Bill of quantities" in .xls (Excel) format electronically (downloadable) instead of pdf, to fill in the sheets electronically.	The documents are attached (No 12).
67	27.05.	TV	ITB Page 10. "The bids including proof of payment of USD 100 or kwacha equivalent must be sent clearly marked "Tender for the Supply, Installation and Commissioning of the New Parliament Television (TV) Studio and the Extension of the existing Radio Transmitter Network for the Parliament Radio at the National Assembly of Zambia – (do not open before Friday, June 17th, 2016", addressed to the Secretary of the National Assembly Procurement Committee and sent not later than Friday, June 17th 2016 14:30 hour's local time. Late bids will be rejected" Regarding proof of payment of USD 100 or kwacha equivalent, how this money should be sent, is there a bank account to transfer the money or what is the preferred option for Procurement Committee?	Send the money to: Account Name: National Assembly of Zambia, Bank: Finance Bank Zambia Limited, Account No: 0090840032019, SWIFT: ZFBAZMLU, SORT CODE: 110009, BANK ADDRESS: FINANCE BANK, BRANCH: ODYS

Request No.	Date	Part of Tender	Requests/Recommendations	Answer
68	27.05.	TV	Difference Appendix 1 - 2 -7, TV Overall Diagram and TV Control Rack Layout – Bill of quantities, an audio mixer is in drawing Appendix 1 but not in 2 and 7, please specify if an audio mixer should be part of the tender.	Audio mixer will not required. Please see update of attachment (8,9,10) For more further informations refer to attachment No 04.
69	27.05.	TV	Difference Appendix 3-7, Drawing 3 contains a KVM Switch 4-1, and a 19" Display, but in the Bill of quantities not requested, please specify if a KVM Switch and additional 19" Display should be part of the tender.	KVM will not required. Please see update of attachment (8,9,10) For more further informations refer to attachment No 04.
70	27.05.	TV	Appendix 1, Fiber cable wiring between the different buildings, connection between IT room and 3x new committee rooms, please specify witch cables and connections are part of the tender. During the technical walkabout the information was not fully clear if parts of the existing cabling can-should be used. An overall diagram with approx. cable length would be very helpful	See answer to request 40 regarding cable types. It will not be possible to use existing cabling See new attachments regarding cable lengths
71	27.05.	TV	Appendix 5 TV Compliance Matrix: Pos. 1.5.29 – Noise reducing 19" Rack, Please check if the aircon flow or location of the TV Control room racks can be changed / modified. This type of racks typical require enough cold air at the bottom rear, if that could not guarantee, the current layout could create issues with noisy fans to the chamber room and equipment temperature inside of the rack	See answer to request to item 17. No additional air conditioning is required.

Request No.	Date	Part of Tender	Requests/Recommendations	Answer
72	27.05.	TV	Appendix 7 Bill of quantities Pos 1.4.2 and 1.4.3 Please check if the position of Embedder, Electrical / Optical converter should be in the IT room - HD SDI copper cable length limitations and quantity of Embedder are matching to a system without audio mixer	Please see new attachments
73	27.05.	TV	Appendix 7 Bill of quantities Pos 1.5 ff Please check if the 3x New Committee room remote camera Operator in control room need DeEmbedder, Headphones / Headphone Amp's and to hear the speakers voice, faster reaction time, better preparation of next camera position. There is currently no equipment in the request list	Please see new attachments
74	27.05.	TV	Appendix 7 Bill of quantities New position in Appendix 5 Bill of quantities "Wallbox" OB Vans, please specify the requirements including if necessary additional 1080i/625 downconverters and Video signal DA's.	Please see new attachments
75	27.05.	TV	Please tell us if all fibre optical cables are already installed in between each building. If yes, please state if singlemode or multimode and type of connectors. If not, please give the exact length needed using the existing cable galleries taking into consideration the distance between the bottom of the buildings to the technical rooms where the fibre must arrive. Please confirm that the fiber between the chamber and ZNBC is singlemode, and if this fiber cable arrives all the way to the TV control room	Regarding the question about single or multimode cable please check specifications of the equipment you are supplying.

Request No.	Date	Part of Tender	Requests/Recommendations	Answer
76	27.05.	TV	What is the height of the main Chamber room ?to figure out how to change the bulbs !! (Lighting not listed in the bill of quantity !)	To change the bulbs is be part of the responsibility by the client.
77	27.05.	TV	Are there existing cableways from the TV control room to the fiber cable arrivals located outside ?	See attached Diagram of cable lengths (05).
78	27.05.	TV	What is the width and the height of the TV control room ? Is there an A/C system, an air blower and air extraction system ?	See answer to request to item 17. No additional air conditioning is required.
79	27.05.	TV	Do you know the number of clients required on the MAM (Media Asset Management) server.	See answer to request No 5.
80	27.05.	TV	In order to figure out the capacity of the archiving system, could you please let us know the average number of parliamentary sessions per year in both Chamber and New committee rooms. (Average hours per session also)	Main Chamber: 82 sittings in a year (Average of sitting 5 hours per sitting), Committee Meetings: 17 sittings in a year (Average of 3 hours per sitting)
81	27.05.	TV	Is there a References distributor in the new IP Room ?	Please see new attachments
82	27.05.	TV	Is there an existing audio mixer to be used in the Tv control room? (Audiomix)(Not listed in the bill of quantity ! but appears on appendix 1)	There is no audio mixer
83	27.05.	Radio	You wish to upgrade 3 Radio transmitters. Please quote Brand, power and exact configuration and reference of existing Radio transmitters.	The brand is BS-electronic. Power=1kW.

Request No.	Date	Part of Tender	Requests/Recommendations	Answer
84	27.05.	TV	Are there any measures to ensure that video and audio remain synchronous in the TV system?	The suggested frame synchronisers / audio embedders include dynamic audio delays
85	27.05.	TV	How should the cameras in the chamber and committee room be powered?	In the chamber the cameras are to be powered via PoE from the Ethernet switch. In the committee rooms the cameras are to be powered via separate PoE adapters, because of the cable lengths from the switch.





TRANSMITTER SHELTER KEY FEATURES

(Not to scale)

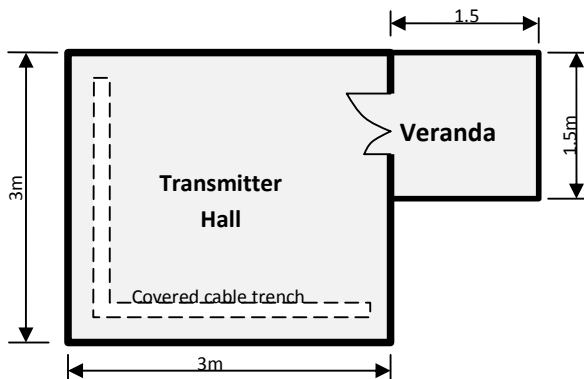

a). Floor Plan

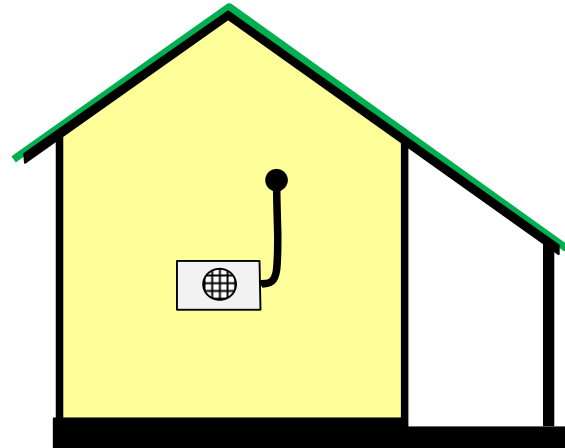

b). Side View

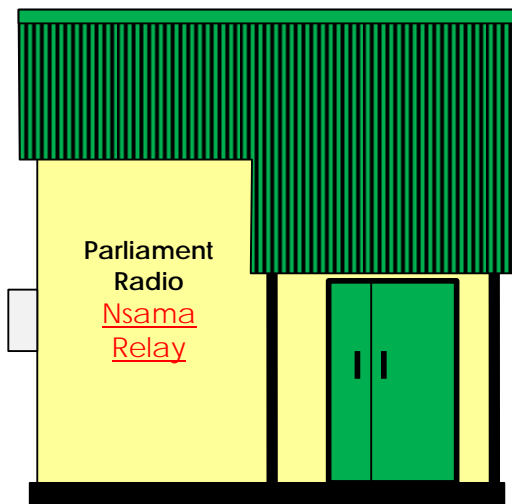

c). Front View

MAJOR CONSIDERATIONS for BRICK SHELTER OPTION.

- Foundation must be treated with anti-termite
- Back-fill must be covered with black Polythene sheet
- Minimum slab thickness should be 100mm.
- Slab must be reinforced with standard con-force wire.
- Brick-force wire must be applied after every 3 courses.
- Brick width should be minimum 5-inch.
- The walls must be plastered both inside and outside.
- Suspended ceiling with ant-fire treated boards.
- Roofing timber must be treated with wood preservative.
- Roofing sheets must be IBR minimum 0.3mm gauge
- The door and door-frame must be fabricated with mild steel
- Appropriate door locking mechanism should be employed

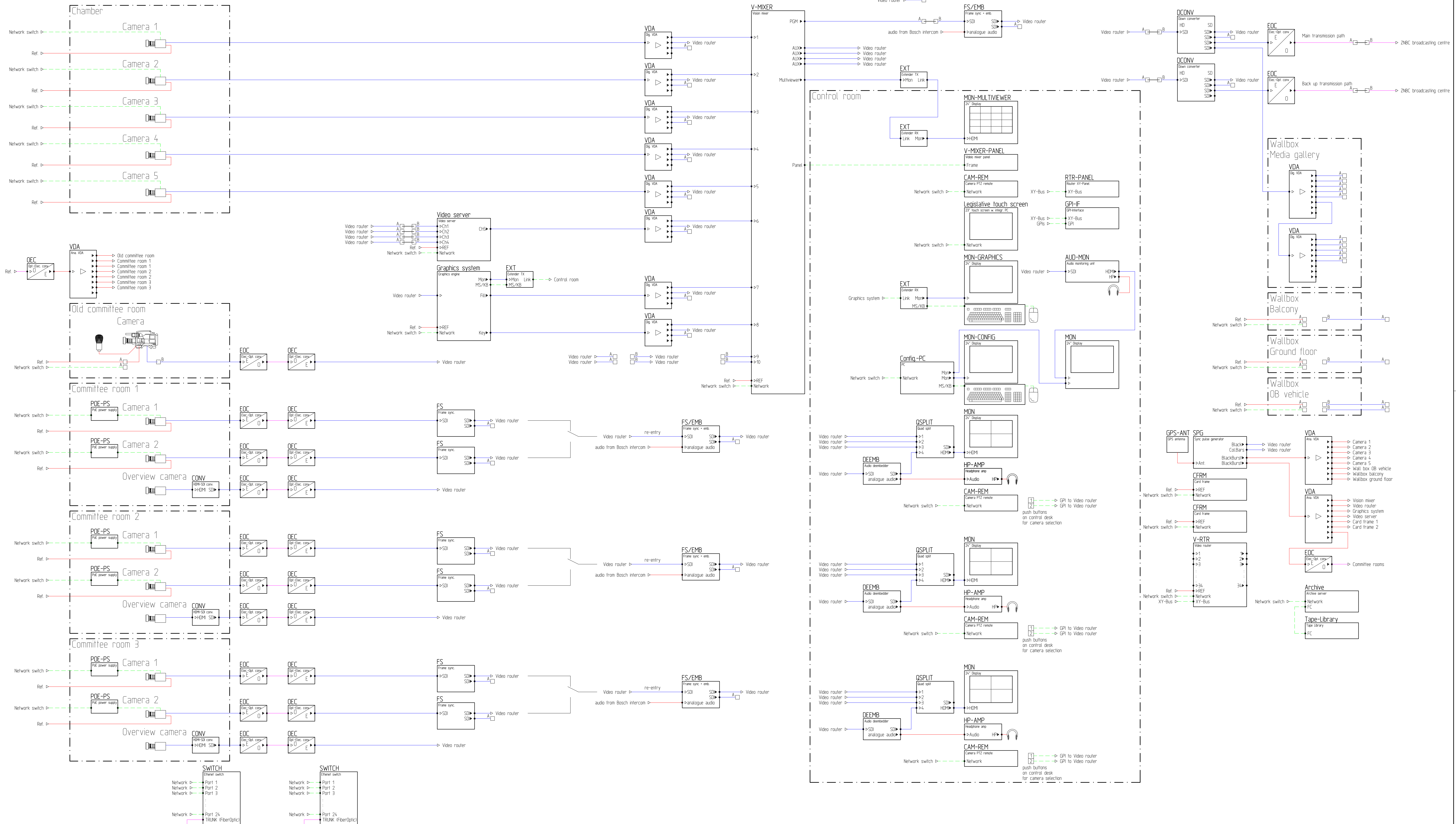

	Date	Name	Project:	Consulting Zambisches Parlament
	Drawn: May 27, 2014	McNamara		
	Check: May 27, 2014	McNamara		
	Design: May 27, 2014	McNamara		
			Tendering Phase	
			Description	
			TV-System	
			Block schematic	
			Drawing-No	Block_schematic
			Cust-Drw-No	A1
Index	Correction	Date	Name	Page

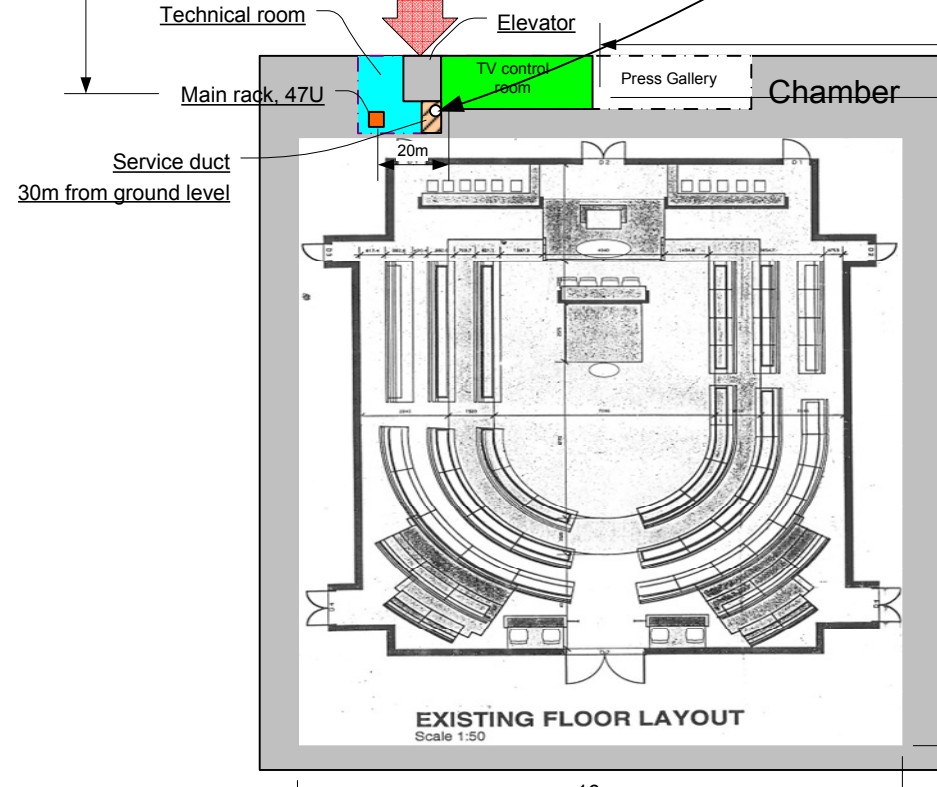
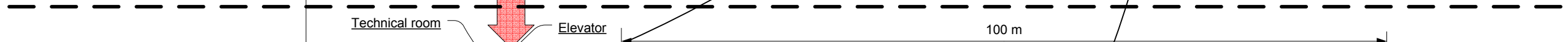
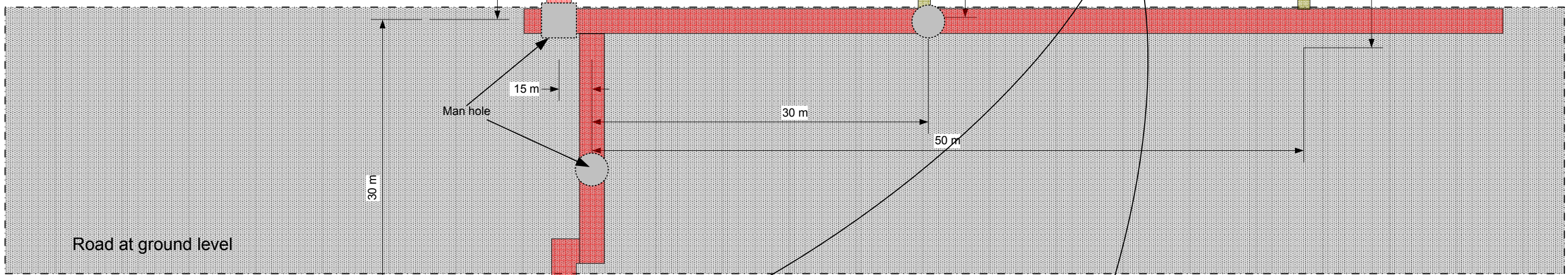
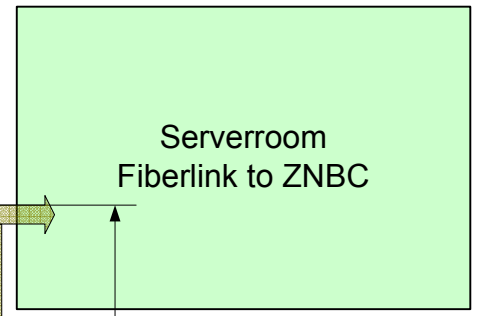
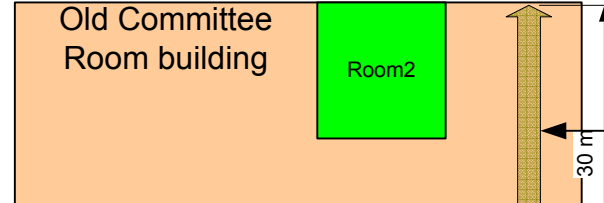
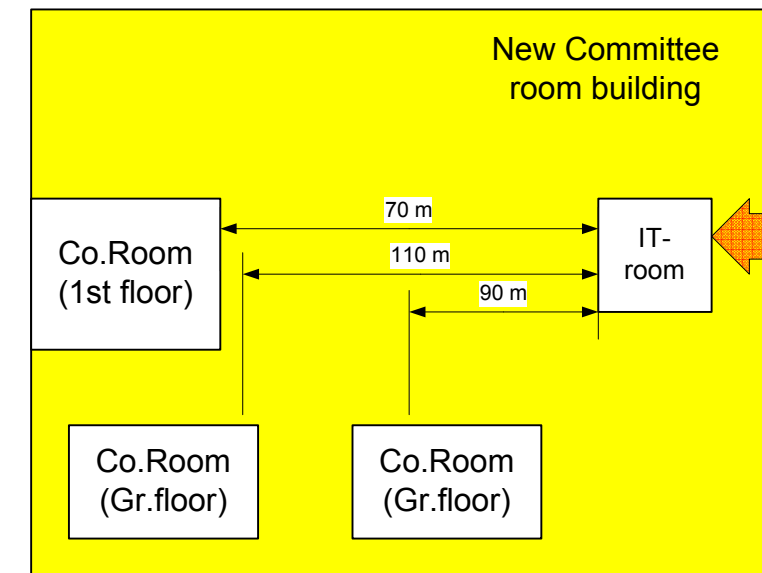

Main Building of Parliament

Note ! All given cable lengths are estimates, bidders must budget for sufficient spare.

TV @ NAZ Zambia			
Cable Ways			
May, 27th 2016	Size: A3	Drawn by: A.Wike	Changed by: A.Wike
SCALE			Attachment No

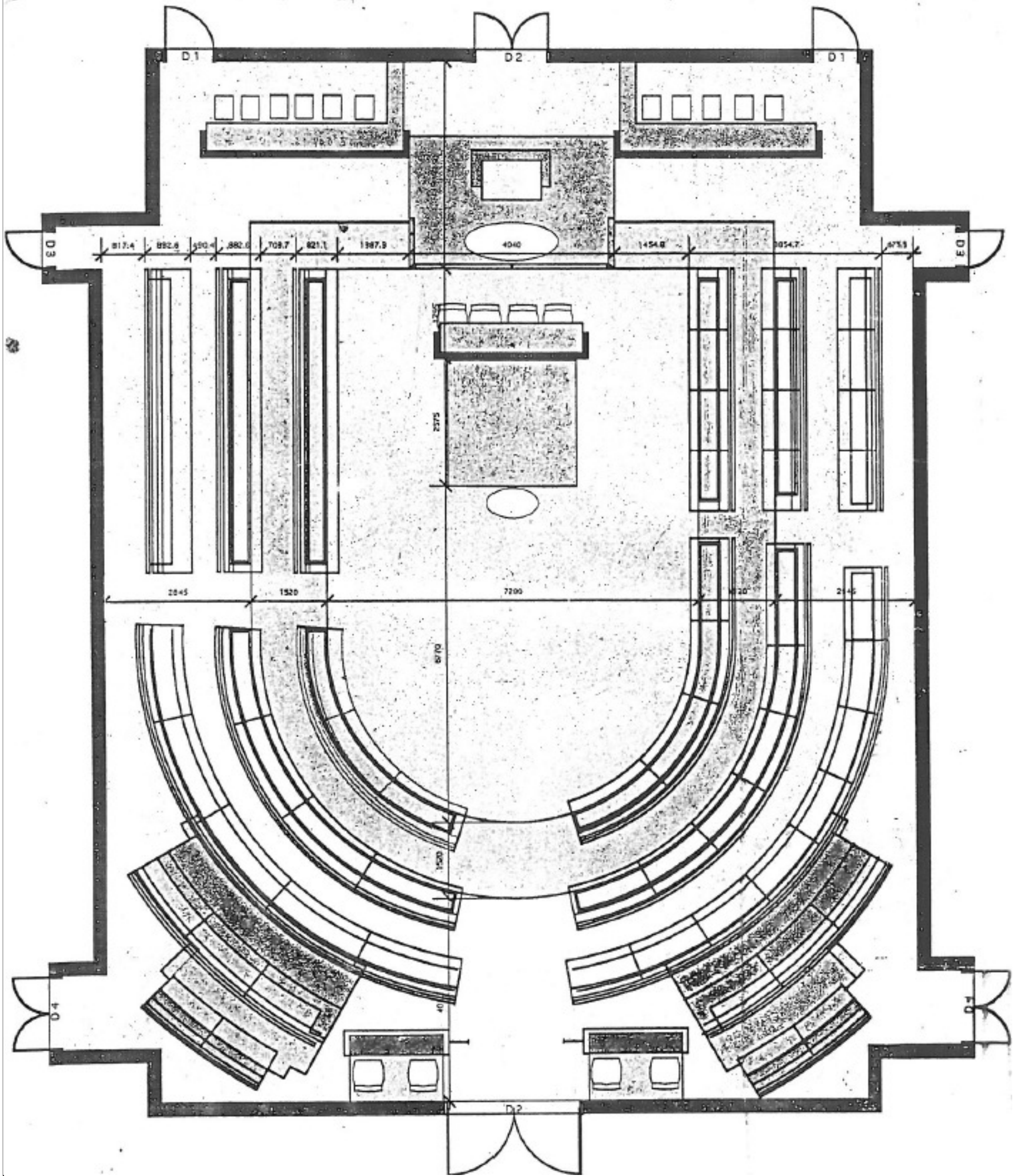

TV @ NAZ Zambia			
Layout of Chamber			
May, 25th 2016	Size A3	Drawn by A.Wike	Changed by A.Wike
SCALE			REV 1.0
Attachment No			

MINISTER OF DEFENCE	MINISTER OF LANDS, NATURAL RESOURCES & ENVIRONMENTAL PROTECTION	MINISTER OF FINANCE	MINISTER OF SUPPLY	MINISTER OF FOREIGN AFFAIRS	MINISTER OF JUSTICE	HER HONOUR THE VICE PRESIDENT & MINISTER OF DEV. PLANNING	MINISTER OF HOME AFFAIRS	MINISTER OF INFO. & BROADCASTING	MINISTER OF YOUTH, SPORTS & CHILD DEV.	MINISTER OF MINES & MINERALS DEV.
MINISTER OF LANDS, NATURAL RESOURCES & ENVIRONMENTAL PROTECTION	MINISTER OF LANDS, NATURAL RESOURCES & ENVIRONMENTAL PROTECTION	MINISTER OF FINANCE	MINISTER OF SUPPLY	MINISTER OF FOREIGN AFFAIRS	MINISTER OF JUSTICE	HER HONOUR THE VICE PRESIDENT & MINISTER OF DEV. PLANNING	MINISTER OF HOME AFFAIRS	MINISTER OF INFO. & BROADCASTING	MINISTER OF YOUTH, SPORTS & CHILD DEV.	MINISTER OF MINES & MINERALS DEV.
MINISTER OF DEFENCE	MINISTER OF LANDS, NATURAL RESOURCES & ENVIRONMENTAL PROTECTION	MINISTER OF FINANCE	MINISTER OF SUPPLY	MINISTER OF FOREIGN AFFAIRS	MINISTER OF JUSTICE	HER HONOUR THE VICE PRESIDENT & MINISTER OF DEV. PLANNING	MINISTER OF HOME AFFAIRS	MINISTER OF INFO. & BROADCASTING	MINISTER OF YOUTH, SPORTS & CHILD DEV.	MINISTER OF MINES & MINERALS DEV.

MR. B. MUYENGA (KALOMO CENTRAL)	MR. G. NKOMO (KALOMO CENTRAL)	MR. M. HAMBUNDU (MAYIYA)	MR. C. MWEETA (CHOMIA CENTRAL)	MR. B. HAMBUNDE (NANCOMA)	MR. V. MOOYA (MOOMBA)	MR. S. KATUKA (MWINILUNGA)	MR. J. MUYIWA (MONZE CENTRAL)	MR. M. M. NYUNDE (GWECHIB)
MR. D. LUYNE (KALOMBOLO)	MRS. C. MAZOKA (PEMBA)	MR. A. MUIAMBHO (MWEKESHI)	MR. C. MUYANDA (MAYIYA)	MR. M. MUYILO (LEKULU WEST)	MR. C. MUYITU (KALABO CENTRAL)	MR. K. HAMBUDU (SIWONGA)	MR. C. MUYOMBA (MAGOVE)	MR. A. LUTEMBA (KAMOTPO WEST)
MR. E. BELLEMI (MIBALATA)	MR. B. K. CHITATA (KAPITAPATA)	MRS. N. LUTHEZHI (NAMWATA)	MR. L. MUYALATI (SENANGA)	MR. V. LOMBARANYA (SOLWEZI EAST)	MR. T. KASONSO (SOLWEZI WEST)	MR. C. ANTONIO (KALOMA CENTRAL)	MR. S. SIANGA (SHEKHE)	MR. T. SHAKAVESWA (KATUBA)

MR. T. BANDU (LEKEZI)	MR. M. MALAMA (CHITAMBORO)	MR. W. BANDA (MILANDA)	MR. M. NDALAMEI (MICHINGA)	MR. R. KANDA (DZEMANYANA)	MR. M. BONGCU (GILVEMBA)	MR. K. KONGA (GILVEMBA)	MR. S. MASHIMBA (MUTUMBE)	MR. C. NAMULAMBWE (MUTUMBE)	MR. W. SIMUSA (NGWANGA)	MR. O. SMWALITETA (KAPFE)	MR. E. MUCHEMA (MELINGO)	MR. A. MBEWE (CHADIZA)	MR. M. SIMBUKWE (MIBATA)	MR. K. MUKATA (CHILANGA)	MR. L. NGOMA (SINDA)	DR. C. KALILA (LURULU EAST)
MR. T. BANDU (LEKEZI)	MR. M. MALAMA (CHITAMBORO)	MR. W. BANDA (MILANDA)	MR. M. NDALAMEI (MICHINGA)	MR. R. KANDA (DZEMANYANA)	MR. M. BONGCU (GILVEMBA)	MR. K. KONGA (GILVEMBA)	MR. S. MASHIMBA (MUTUMBE)	MR. C. NAMULAMBWE (MUTUMBE)	MR. W. SIMUSA (NGWANGA)	MR. O. SMWALITETA (KAPFE)	MR. E. MUCHEMA (MELINGO)	MR. A. MBEWE (CHADIZA)	MR. M. SIMBUKWE (MIBATA)	MR. K. MUKATA (CHILANGA)	MR. L. NGOMA (SINDA)	DR. C. KALILA (LURULU EAST)
MR. T. BANDU (LEKEZI)	MR. M. MALAMA (CHITAMBORO)	MR. W. BANDA (MILANDA)	MR. M. NDALAMEI (MICHINGA)	MR. R. KANDA (DZEMANYANA)	MR. M. BONGCU (GILVEMBA)	MR. K. KONGA (GILVEMBA)	MR. S. MASHIMBA (MUTUMBE)	MR. C. NAMULAMBWE (MUTUMBE)	MR. W. SIMUSA (NGWANGA)	MR. O. SMWALITETA (KAPFE)	MR. E. MUCHEMA (MELINGO)	MR. A. MBEWE (CHADIZA)	MR. M. SIMBUKWE (MIBATA)	MR. K. MUKATA (CHILANGA)	MR. L. NGOMA (SINDA)	DR. C. KALILA (LURULU EAST)

MINISTER OF DEFENCE	MINISTER OF LANDS, NATURAL RESOURCES & ENVIRONMENTAL PROTECTION	MINISTER OF FINANCE	MINISTER OF SUPPLY	MINISTER OF FOREIGN AFFAIRS	MINISTER OF JUSTICE	HER HONOUR THE VICE PRESIDENT & MINISTER OF DEV. PLANNING	MINISTER OF HOME AFFAIRS	MINISTER OF INFO. & BROADCASTING	MINISTER OF YOUTH, SPORTS & CHILD DEV.	MINISTER OF MINES & MINERALS DEV.
MINISTER OF DEFENCE	MINISTER OF LANDS, NATURAL RESOURCES & ENVIRONMENTAL PROTECTION	MINISTER OF FINANCE	MINISTER OF SUPPLY	MINISTER OF FOREIGN AFFAIRS	MINISTER OF JUSTICE	HER HONOUR THE VICE PRESIDENT & MINISTER OF DEV. PLANNING	MINISTER OF HOME AFFAIRS	MINISTER OF INFO. & BROADCASTING	MINISTER OF YOUTH, SPORTS & CHILD DEV.	MINISTER OF MINES & MINERALS DEV.
MINISTER OF DEFENCE	MINISTER OF LANDS, NATURAL RESOURCES & ENVIRONMENTAL PROTECTION	MINISTER OF FINANCE	MINISTER OF SUPPLY	MINISTER OF FOREIGN AFFAIRS	MINISTER OF JUSTICE	HER HONOUR THE VICE PRESIDENT & MINISTER OF DEV. PLANNING	MINISTER OF HOME AFFAIRS	MINISTER OF INFO. & BROADCASTING	MINISTER OF YOUTH, SPORTS & CHILD DEV.	MINISTER OF MINES & MINERALS DEV.

MR. T. BANDU (LEKEZI)	MR. M. MALAMA (CHITAMBORO)	MR. W. BANDA (MILANDA)	MR. M. NDALAMEI (MICHINGA)	MR. R. KANDA (DZEMANYANA)	MR. M. BONGCU (GILVEMBA)	MR. K. KONGA (GILVEMBA)	MR. S. MASHIMBA (MUTUMBE)	MR. C. NAMULAMBWE (MUTUMBE)	MR. W. SIMUSA (NGWANGA)	MR. O. SMWALITETA (KAPFE)	MR. E. MUCHEMA (MELINGO)	MR. A. MBEWE (CHADIZA)	MR. M. SIMBUKWE (MIBATA)	MR. K. MUKATA (CHILANGA)	MR. L. NGOMA (SINDA)	DR. C. KALILA (LURULU EAST)
MR. T. BANDU (LEKEZI)	MR. M. MALAMA (CHITAMBORO)	MR. W. BANDA (MILANDA)	MR. M. NDALAMEI (MICHINGA)	MR. R. KANDA (DZEMANYANA)	MR. M. BONGCU (GILVEMBA)	MR. K. KONGA (GILVEMBA)	MR. S. MASHIMBA (MUTUMBE)	MR. C. NAMULAMBWE (MUTUMBE)	MR. W. SIMUSA (NGWANGA)	MR. O. SMWALITETA (KAPFE)	MR. E. MUCHEMA (MELINGO)	MR. A. MBEWE (CHADIZA)	MR. M. SIMBUKWE (MIBATA)	MR. K. MUKATA (CHILANGA)	MR. L. NGOMA (SINDA)	DR. C. KALILA (LURULU EAST)
MR. T. BANDU (LEKEZI)	MR. M. MALAMA (CHITAMBORO)	MR. W. BANDA (MILANDA)	MR. M. NDALAMEI (MICHINGA)	MR. R. KANDA (DZEMANYANA)	MR. M. BONGCU (GILVEMBA)	MR. K. KONGA (GILVEMBA)	MR. S. MASHIMBA (MUTUMBE)	MR. C. NAMULAMBWE (MUTUMBE)	MR. W. SIMUSA (NGWANGA)	MR. O. SMWALITETA (KAPFE)	MR. E. MUCHEMA (MELINGO)	MR. A. MBEWE (CHADIZA)	MR. M. SIMBUKWE (MIBATA)	MR. K. MUKATA (CHILANGA)	MR. L. NGOMA (SINDA)	DR. C. KALILA (LURULU EAST)

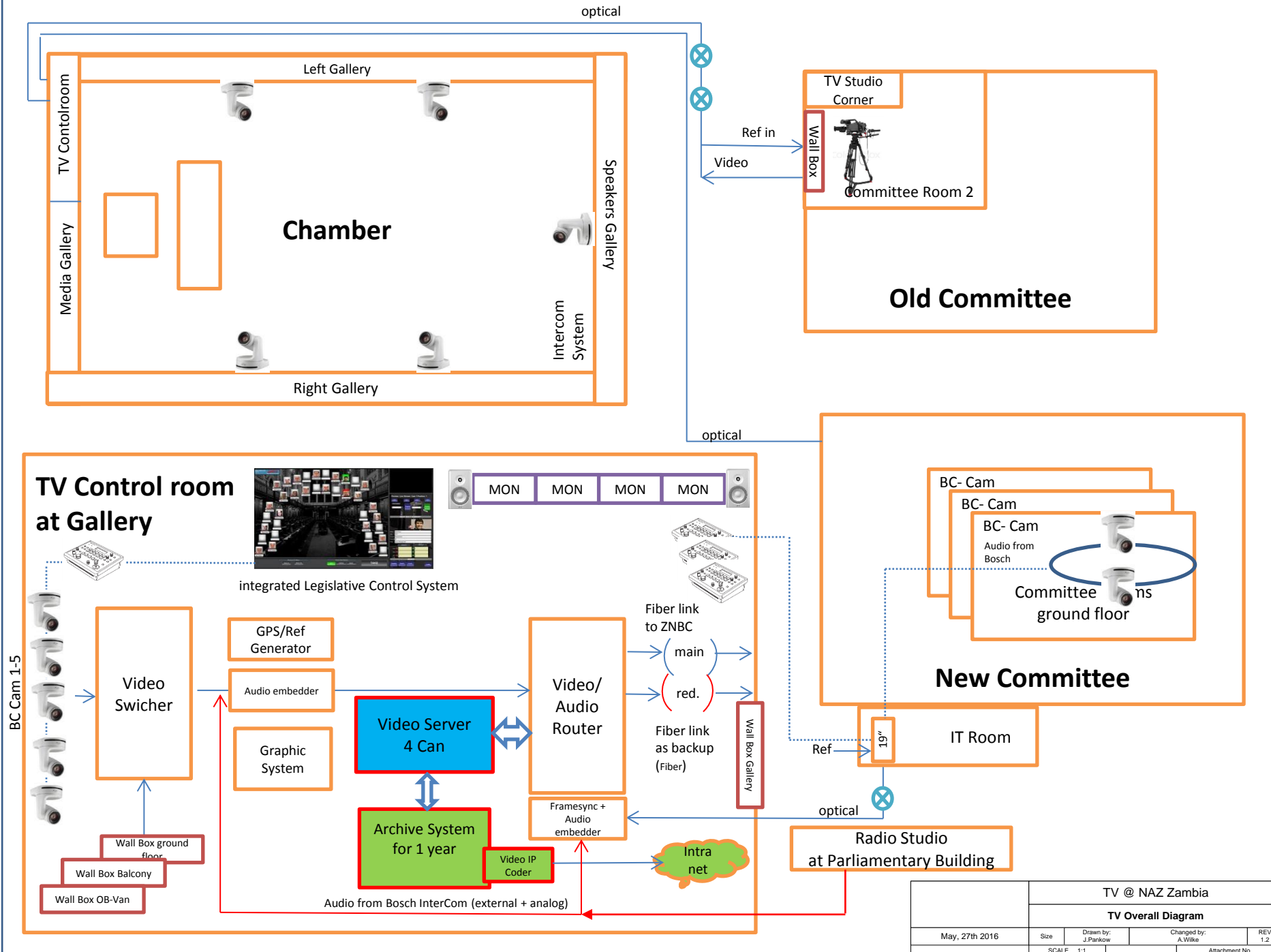

TV @ NAZ Zambia				
TV Overall Diagram				
May, 27th 2016	Size	Drawn by: J.Pankow	Changed by: A.Wilke	REV 1.2
SCALE 1:1		Attachment No		

Racks for TV studio

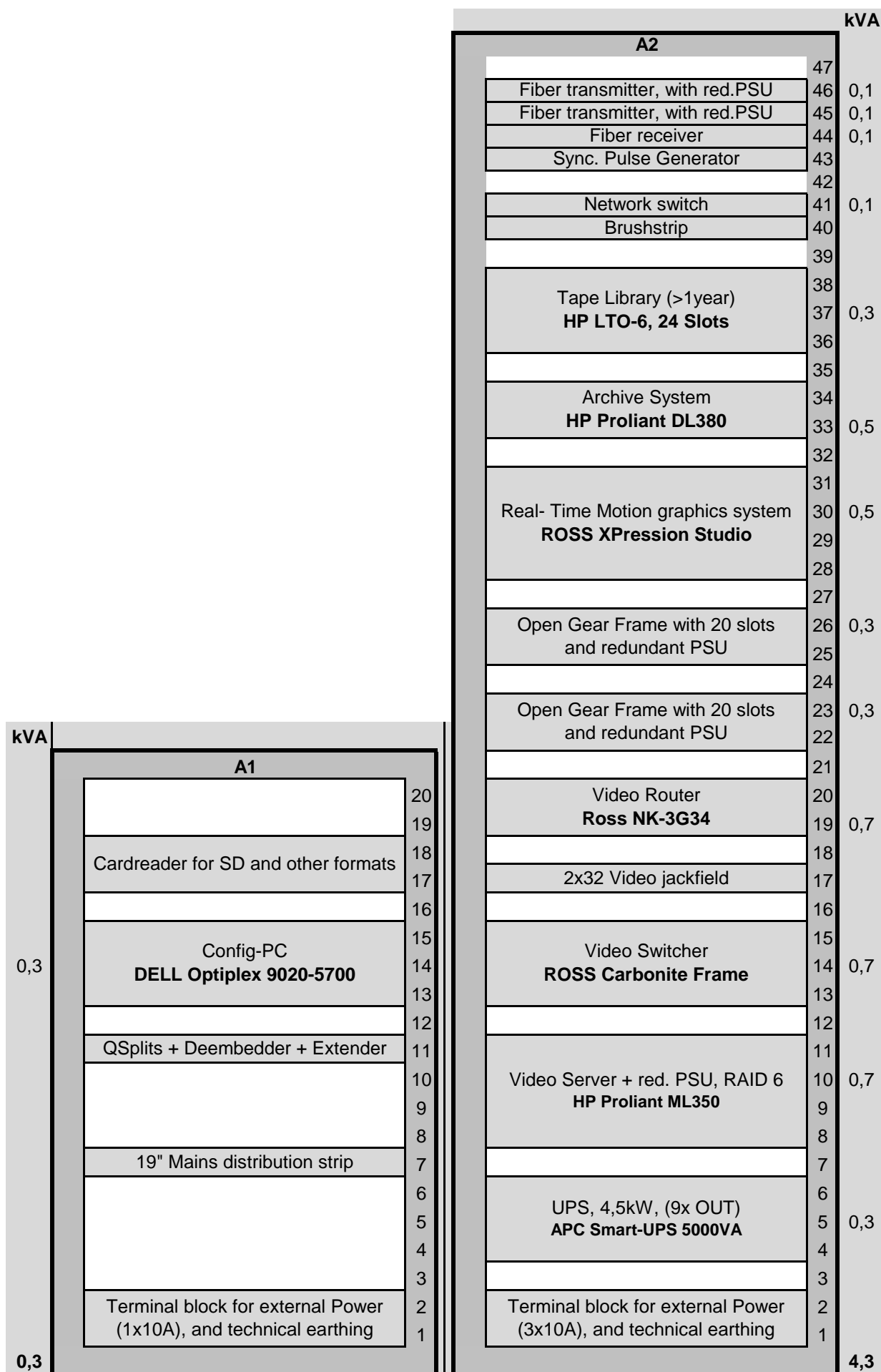

**Strengthening Parliamentary Control
in Zambia,
LOT 1- New TV-Studio**

Extra Bill of Quantity
(to be completed by the bidder)

Item	Manufact.	Description	Type	Comment	Qty. pcs.	Retail Price	Retail Price
						per unit	main item tot.
						Euro	Euro
1		Equipment					
1.5		Control Room					
1.5.40	Lake People or equivalent	Headphone amp, 2 channel analogue audio sym.	PHONE-AMP F388 S	new	3	- €	- €
1.5.41	Sennheiser or equivalent	stereo headphones impedance: 60 ohms frequency response: 30Hz-16KHz (-3dB)	HD 25-SP II	additional	3	- €	- €
1.5.42	Samsung or equivalent	Monitor 24" 1920 x 1080 Full HD VGA, HDMI	S22E390H	additional	1	- €	- €
1.5.43	Ross or equivalent	1x8 reference distribution	VEA-8707A-R2A	new	1	- €	- €
1.5.44	Ross or equivalent	HD / SD SDI Frame Synch w/ 8x Analog Audio Input	SFS-8622A-IC-R2C	new	4	- €	- €
1.5.45	Ross or equivalent	HD / SD SDI Frame Synchronizer	SFS-8622A-A-R2A	new	6	- €	- €
1.5.46	Ross or equivalent	Frame for openGear Cards 20 openGear card slots, 1 controller slot, and 1 reference slot Includes basic network controller, reference card, cooling system and one power supply	OG3-FR-C	new	1	- €	- €
1.5.47	Ross or equivalent	Redundant power supply	PS-OG3	new	1	- €	- €
1.5.48	Dell or equivalent	PC Keyboard with standard layout, USB	KB212	new	2	- €	- €
1.5.49	Dell or equivalent	Optical mouse, 3 button, USB	MS111	new	2	- €	- €
1.5.50	Kramer or equivalent	1x8 reference distribution, size - compact desktop	VM-80VN	new	1	- €	- €

**Strengthening Parliamentary Control
in Zambia,
LOT 1- New TV-Studio**

Extra Bill of Quantity
(to be completed by the bidder)

Item	Manufact.	Description	Type	Comment	Qty. pcs.	Retail Price	Retail Price
						per unit	main item tot.
						Euro	Euro
1.5.51	Blackmagic or equivalent	HD-SDI distribution amplifier, compact design, connects a single source to 8 re-clocked outputs	Mini Converter SDI Distribution	new	2	- €	- €
1.5.52	Kramer or equivalent	Composite Video Optical Transmitter Bandwidth - 55MHz (-3dB) Level (Gain) and EQ (Peaking) Controls	611T	new	1	- €	- €
1.5.53	Kramer or equivalent	Composite Video Optical Receiver Bandwidth - 55MHz (-3dB) Level (Gain) and EQ (Peaking) Controls	611R	new	1	- €	- €
1.5.54	G&D or equivalent	KVM extender, transmission of DVI signals via CAT, up to 140 m transmission length, receiver	DVI-Vision-CAT-AR-CON	new	1	- €	- €
1.5.55	G&D or equivalent	KVM extender, transmission of DVI signals via CAT, up to 140 m transmission length, transmitter	DVI-Vision-CAT-AR-CPU	new	1	- €	- €
1.5.56	Canare or equivalent	Video jackfield, 2x32, self-normalling, mid-size, 'mini-WEC0' style	32MD-ST	new	1	- €	- €
1.5.57	Canare or equivalent	Video patchcord 300 mm	MVPC003	new	10	- €	- €
1.5.58	n.n.	Wallbox OB Vehicle (2x Video, Power socket, 1x network), weather proof		new	1	- €	- €
1.5.59	Blackmagic or equivalent	HD-SDI Audio deembedder, 4ch. Analogue	SDI-Audio	new	3	- €	- €
1.5.60	Ross or equivalent	High quality downconverter with 4 reclocked outputs and 4 configurable SD/analog outputs	HDC-8223-R2	additional 	1	- €	- €
1.5.61	Decimator or equivalent	HD-SDI-HDMI converter	Decimator 2	additional 	1	- €	- €

**Strengthening Parliamentary Control
in Zambia,
LOT 1- New TV-Studio**

Extra Bill of Quantity
(to be completed by the bidder)

Item	Manufact.	Description	Type	Comment	Qty. pcs.	Retail Price	Retail Price
						per unit	main item tot.
						Euro	Euro
1.5.62	Cisco or equivalent	28-Port GB-Switch 24x GB-LAN, mini-GBIC Managed, VLAN, PoE+ 2x Gigabit Ethernet Mini GBIC fiber transceiver	SG300-28MP MGBLH1	Ammended replacem ent for position: 1.5.1	1	- €	- €
1.5.63	Broaman or equivalent	Fiber transmitter 1x SDI(SD/HD/3G) In reclocked, redundant fibre transmitter Channel status LEDs Built-in dual power supply with automatic switchover 1RU design		Ammended replacem ent for position: 1.6.3	1	- €	- €
1.5.64	Broaman or equivalent	Fiber receiver 1x SDI(SD/HD/3G) Out, redundant fibre receiver with automatic change over unit Channel status LEDs Built-in dual power supply with automatic switchover 1RU design		Ammended replacem ent for position: 1.6.3	1	- €	- €
1.5.65	n.n.	Rack cabinet 19 inch, with Fan, Filter mat 47RU, 1000mm depth, with glass front door	see Att. 10	Ammended replacem ent for position: 1.5.29	1		- €

**Strengthening Parliamentary Control
in Zambia,
LOT 1- New TV-Studio**

Extra Bill of Quantity
(to be completed by the bidder)

Item	Manufact.	Description	Type	Comment	Qty. pcs.	Retail Price	Retail Price
						per unit	main item tot.
						Euro	Euro
1.5.66	n.n.	Rack cabinet 19 inch 16RU, 600mm depth, with glass front door	see Att. 10	new	1	- €	- €
1.5.67	APC or equivalent	Uninterruptible power supply 5000 VA, runtime 5 minutes full load, 3RU rackmountable power conditioner	SUA5000RMXL I3U	Ammend ed replacem ent for position: 1.5.30	1	- €	- €
		Totalsum net			1		- €
		Freight, CIP (Carriage Insurance Paid) to NAZ, Lusaka	INCOTERMS		1	- €	- €
		Totalsum net, incl. Freight and Insurance			1		- €

Panasonic®

Operating Instructions <Basics>

Remote Camera Controller

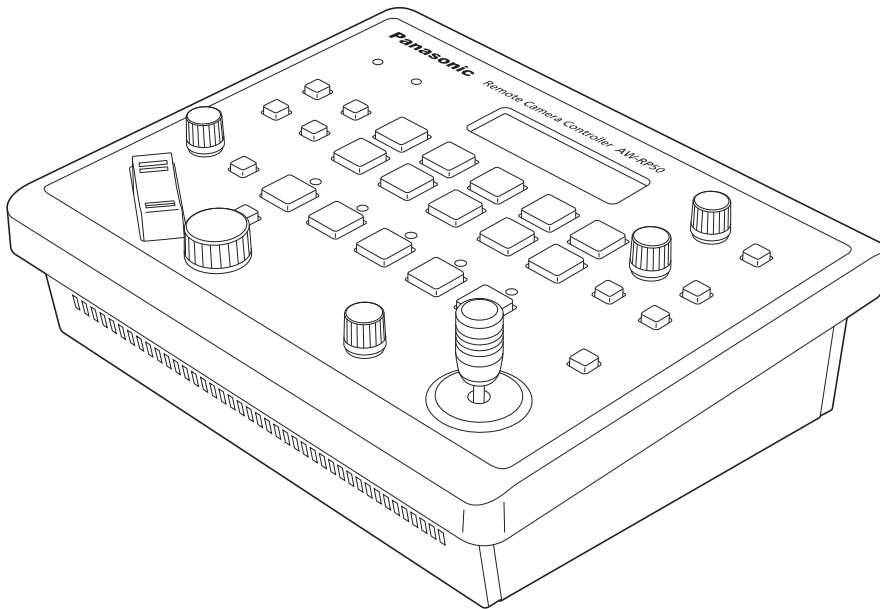

Model No. **AW-RP50N**



Before operating this product, please read the instructions carefully and save this manual for future use.

For instructions on how to operate this Remote Camera Controller and how to establish its settings, refer to the “Operations and Settings” manual (PDF file) which can be found on the CD-ROM supplied with the camera.

Safety precautions

	CAUTION RISK OF ELECTRIC SHOCK DO NOT OPEN	
CAUTION: TO REDUCE THE RISK OF ELECTRIC SHOCK, DO NOT REMOVE COVER (OR BACK). NO USER SERVICEABLE PARTS INSIDE. REFER TO SERVICING TO QUALIFIED SERVICE PERSONNEL.		



The lightning flash with arrowhead symbol, within an equilateral triangle, is intended to alert the user to the presence of uninsulated “dangerous voltage” within the product’s enclosure that may be of sufficient magnitude to constitute a risk of electric shock to persons.



The exclamation point within an equilateral triangle is intended to alert the user to the presence of important operating and maintenance (service) instructions in the literature accompanying the appliance.

WARNING:

■ THIS APPARATUS MUST BE EARTHED

To ensure safe operation, the three-pin plug must be inserted only into a standard three-pin power point which is effectively earthed through the normal household wiring.

Extension cords used with the apparatus must have three cores and be correctly wired to provide connection to the earth. Wrongly wired extension cords are a major cause of fatalities.

The fact that the apparatus operates satisfactorily does not imply that the power point is earthed or that the installation is completely safe. For your safety, if you are in any doubt about the effective earthing of the power point, please consult a qualified electrician.

—For CANADA—

This class A digital apparatus complies with Canadian ICES-003.

Cet appareil numérique de la classe A est conforme à la norme NMB-003 du Canada.

WARNING:

- TO REDUCE THE RISK OF FIRE OR ELECTRIC SHOCK, DO NOT EXPOSE THIS APPARATUS TO RAIN OR MOISTURE.
- THE APPARATUS SHALL NOT BE EXPOSED TO DRIPPING OR SPLASHING AND THAT NO OBJECTS FILLED WITH LIQUIDS, SUCH AS VASES, SHALL BE PLACED ON THE APPARATUS.

CAUTION:

TO REDUCE THE RISK OF FIRE OR SHOCK HAZARD AND ANNOYING INTERFERENCE, USE THE RECOMMENDED ACCESSORIES ONLY.

FCC Note:

This equipment has been tested and found to comply with the limits for a class A digital device, pursuant to Part 15 of the FCC Rules. These limits are designed to provide reasonable protection against harmful interference when the equipment is operated in a commercial environment. This equipment generates, uses, and can radiate radio frequency energy, and if not installed and used in accordance with the instruction manual, may cause harmful interference to radio communications. Operation of this equipment in a residential area is likely to cause harmful interference in which case the user will be required to correct the interference at his own expense.

Warning:

To assure continued FCC emission limit compliance, the user must use only shielded interface cables when connecting to external units. Also, any unauthorized changes or modifications to this equipment could void the user’s authority to operate it.

CAUTION:

In order to maintain adequate ventilation, do not install or place this unit in a bookcase, built-in cabinet or any other confined space. To prevent risk of electric shock or fire hazard due to overheating, ensure that curtains and any other materials do not obstruct the ventilation.

The socket outlet shall be installed near the equipment and easily accessible or the mains plug or an appliance coupler shall remain readily operable.

A warning that an apparatus with CLASS 1 construction shall be connected to a MAINS socket outlet with a protective earthing connection.

Safety precautions

IMPORTANT SAFETY INSTRUCTIONS

Read these operating instructions carefully before using the unit. Follow the safety instructions on the unit and the applicable safety instructions listed below. Keep these operating instructions handy for future reference.

- 1) Read these instructions.
- 2) Keep these instructions.
- 3) Heed all warnings.
- 4) Follow all instructions.
- 5) Do not use this apparatus near water.
- 6) Clean only with dry cloth.
- 7) Do not block any ventilation openings. Install in accordance with the manufacturer's instructions.
- 8) Do not install near any heat sources such as radiators, heat registers, stoves, or other apparatus (including amplifiers) that produce heat.
- 9) Do not defeat the safety purpose of the polarized or grounding-type plug. A polarized plug has two blades with one wider than the other. A grounding-type plug has two blades and a third grounding prong. The wide blade or the third prong are provided for your safety. If the provided plug does not fit into your outlet, consult an electrician for replacement of the obsolete outlet.
- 10) Protect the power cord from being walked on or pinched particularly at plugs, convenience receptacles, and the point where they exit from the apparatus.
- 11) Only use attachments/accessories specified by the manufacturer.
- 12) Use only with the cart, stand, tripod, bracket, or table specified by the manufacturer, or sold with the apparatus. When a cart is used, use caution when moving the cart/apparatus combination to avoid injury from tip-over. 
- 13) Unplug this apparatus during lightning storms or when unused for long periods of time.
- 14) Refer all servicing to qualified service personnel. Servicing is required when the apparatus has been damaged in any way, such as power-supply cord or plug is damaged, liquid has been spilled or objects have fallen into the apparatus, the apparatus has been exposed to rain or moisture, does not operate normally, or has been dropped.

 indicates safety information.

Contents

Before use	5	Basic operations of the unit	16
Overview	5	Basic operations for the menus	17
Trademarks and registered trademarks	5	Network settings	18
About copyright and licence	5	Setting the unit	18
Concerning the ratings display	5	Connections	21
Disclaimer of warranty	5	Example of IP connections	21
Network security	5	Example of serial connections	22
Characteristics	6	Settings for connection with the remote cameras	25
Pan-tilt heads and cameras supported	7	Setting the IP addresses automatically (auto IP setting)	26
Accessories	7	Changing the IP addresses of the camera numbers controlled by the unit	33
Required personal computer environment	8	Changing the camera numbers	34
Installation precautions	9	Changing the IP address of the switcher	34
Operating precautions	11	Clearing the IP address control tables	34
Parts and their functions	12	Selecting the remote cameras to be operated	35
Control panel	12	Appearance	37
Rear panel	15	Specifications	38

How the model's Operating Instructions manuals are configured

- The manual of this Remote Camera Controller (hereafter, "the unit") is divided into two manuals: one is the <Basics> (this manual), and the other is the <Operations and Settings> (CD-ROM). Before installing the unit, be sure to read the <Basics> to ensure that the unit is installed correctly.
- This manual explains how to install the unit, and it details the network connection and setting procedures.
For details on how to operate the unit and select its settings, refer to the "Operating Instructions <Operations and Settings>" (PDF file) on the CD-ROM supplied with the unit.
To read PDF files, you will need Adobe® Reader® which is available from Adobe Systems.
- For the purposes of this manual, the model numbers of the units are given as listed in the table below.

Model number of unit	Model number given in manual	Model number of unit	Model number given in manual
AW-HS50N	AW-HS50	AW-E860N	AW-E860
AW-HE50HN	AW-HE50	AW-PH360N	AW-PH360
AW-HE50SN	AW-HE50	AW-PH400P	AW-PH400
AW-HE100N	AW-HE100	AW-PH405N	AW-PH405
AW-HE870N	AW-HE870	AW-PH650N	AW-PH650
AW-E350P	AW-E350	AW-IF400G	AW-IF400
AW-E650P	AW-E650	AK-HC1500G	AK-HC1500
AW-E750P	AW-E750	AK-HC1800G	AK-HC1800

- In these instructions, the phrases "pan-tilt head and camera combination" and "camera integrated with a pan-tilt head" are both referred to collectively as "**remote camera**" except in places where specific equipment is mentioned.

Before use

■ Overview

This unit is a controller which is designed to control remote cameras (cameras integrated with pan-tilt heads) and pan-tilt head systems (which consist of pan-tilt heads and the cameras which are mounted on them).

By means of an IP connection, an operating environment where the unit is tied in with the AW-HE50 HD integrated camera and AW-HS50 compact live switcher is achieved.

When IP connections are used, the unit can be used to control up to 100 remote cameras.

When serial connections are used, up to five remote cameras and pan-tilt head systems can be controlled.

■ Trademarks and registered trademarks

- Microsoft, Windows, Windows Vista, Windows 7 and Internet Explorer are either registered trademarks or trademarks of Microsoft Corporation in the United States and other countries.
- Intel and Intel Core are trademarks or registered trademarks of Intel Corporation in the United States and other countries.
- Adobe and Reader are either registered trademarks or trademarks of Adobe Systems Incorporated in the United States and/or other countries.
- Other names of companies and products contained in these Operating Instructions may be trademarks or registered trademarks of their respective owners.

■ About copyright and licence

Distributing, copying, disassembling, reverse compiling, reverse engineering, and also exporting in violation of export laws of the software provided with this unit are expressly prohibited.

■ Concerning the ratings display

The unit's name, model number and electrical ratings are indicated on its bottom panel.

■ Disclaimer of warranty

IN NO EVENT SHALL Panasonic System Networks Co., Ltd. BE LIABLE TO ANY PARTY OR ANY PERSON, EXCEPT FOR REPLACEMENT OR REASONABLE MAINTENANCE OF THE PRODUCT, FOR THE CASES, INCLUDING BUT NOT LIMITED TO BELOW:

- ① ANY DAMAGE AND LOSS, INCLUDING WITHOUT LIMITATION, DIRECT OR INDIRECT, SPECIAL, CONSEQUENTIAL OR EXEMPLARY, ARISING OUT OF OR RELATING TO THE PRODUCT;
- ② PERSONAL INJURY OR ANY DAMAGE CAUSED BY INAPPROPRIATE USE OR NEGLIGENT OPERATION OF THE USER;
- ③ UNAUTHORIZED DISASSEMBLE, REPAIR OR MODIFICATION OF THE PRODUCT BY THE USER;
- ④ INCONVENIENCE OR ANY LOSS ARISING WHEN IMAGES ARE NOT DISPLAYED, DUE TO ANY REASON OR CAUSE INCLUDING ANY FAILURE OR PROBLEM OF THE PRODUCT;
- ⑤ ANY PROBLEM, CONSEQUENTIAL INCONVENIENCE, OR LOSS OR DAMAGE, ARISING OUT OF THE SYSTEM COMBINED BY THE DEVICES OF THIRD PARTY;
- ⑥ ANY INCONVENIENCE, DAMAGES OR LOSSES RESULTING FROM ACCIDENTS CAUSED BY AN INADEQUATE INSTALLATION METHOD OR ANY FACTORS OTHER THAN A DEFECT IN THE PRODUCT ITSELF;
- ⑦ LOSS OF REGISTERED DATA CAUSED BY ANY FAILURE;
- ⑧ ANY DAMAGES, CLAIMS, ETC. DUE TO LOSS OR LEAKAGE OF THE SETTING DATA SAVED ON THIS UNIT OR IN A PERSONAL COMPUTER.

■ Network security

As you will use this unit connected to a network, your attention is called to the following security risks.

- ① Leakage or theft of information through this unit
- ② Use of this unit for illegal operations by persons with malicious intent
- ③ Interference with or stoppage of this unit by persons with malicious intent

It is your responsibility to take precautions such as those described below to protect yourself against the above network security risks.

- Use this unit in a network secured by a firewall, etc.
- If this unit is connected to a network that includes PCs, make sure that the system is not infected by computer viruses or other malicious entities (using a regularly updated antivirus program, anti-spyware program, etc.).
- Refrain from connections that use public lines.

Characteristics

Compact design

- The unit features a compact design with its half-rack size width (210 mm [8-1/4"]) and its 4RU size (177 mm [6-15/16"]) depth. The unit is the same size as the AW-HS50 compact live switcher (option), and when the switcher is placed alongside the unit, the two units are housed in the full rack width.

IP connection and serial connection supported

IP connection

- Up to 100 remote cameras(*1) can be controlled through a network hub (switching hub).
- Using the unit's automatic IP setting function, the IP addresses of the remote cameras(*1) and switcher(*2) can be assigned and controlled automatically.

*1: Camera supported: AW-HE50
*2: Switcher supported: AW-HS50

- Up to five units can be connected to the same network to control the remote cameras simultaneously.
- Using the Setup Software provided by the camera controller, it is possible to set the IP addresses of the remote cameras and switchers from a PC via the camera controller.

Serial connection

- Up to five remote cameras or pan-tilt head systems can be controlled.

Easy to operate the cameras

- The pan, tilt, zoom, focus and iris operations of the cameras can be easily performed from the unit.
- The gain, shutter, detail, white balance and black balance adjustments can be performed on the unit's LCD menu. (The adjustment items and range differ depending on the cameras connected.)

Easy to operate the preset memory data of the pan-tilt heads

- Up to 100 sets of preset memory data of the pan-tilt heads can be registered and then recalled later.

Function for linkup with the switcher using IP connection

- By linking the unit with one AW-HS50 compact live switcher using an IP connection to make the connection between them, a highly efficient operating environment is achieved.

Camera information display

- The camera setting information (such as the lens iris and gain setting) imported by the unit can be shown on the AUX image output from the switcher or on the split-screen display multi view display.

Tally information imported

- The switcher's ON AIR tally information is imported, and the tally indicators (above the CAMERA STATUS/SELECTION buttons) on the panel are lighted.

Bus material selection

- The switcher's bus materials can be selected from the unit. By pressing the CAMERA STATUS/SELECTION button, these materials can be switched.

Control buses supported: AUX, PVW, PinP, KEY-F

Using a single-step action to operate one of these buttons, the switcher's multi view screen can be switched to a full-screen display on which to show the camera images. (Focus assist function)

Control buses supported: AUX

Parameter changes

- Using the unit's PAN/TILT lever or ZOOM button, the PinP position and other parameters of the switcher can be changed.

Pan-tilt heads and cameras supported

■ Remote cameras supported (cameras integrated with a pan-tilt head)

AW-HE100, AW-HE50

■ Pan-tilt heads supported

AW-PH360, AW-PH405, AW-PH650, AW-PH400 (AW-IF400 required)

■ Cameras supported (must be combined with the pan-tilt head supported)

AW-HE870, AW-E860, AW-E750, AW-E650, AW-E350, AK-HC1500, AK-HC1800

Notes

- Prior to use, be absolutely sure to set the movement ranges (limiters).
- When serial connections are used for the unit and remote cameras or pan-tilt head systems, the cables can be extended up to 1000 meters (3280 ft.).

In these instructions, the phrases “pan-tilt head and camera combination” and “camera integrated with a pan-tilt head” are both referred to collectively as “**remote camera**” except in places where specific equipment is referred to.

Accessories

Check that the following accessories are present and accounted for.

Operating Instructions <Basics> (this manual)	1	AC adapter	1
CD-ROM	1	Power cable	1
● Operating Instructions <Basics>			
● Operating Instructions <Operations and Settings>			
● Setup Software			

Required personal computer environment

Run the software that is provided with the switcher on a host computer which satisfies the following specifications.

CPU	Intel® Core™2 DUO 2.4 GHz or faster recommended
Memory	Windows® XP: 512 MB or more Microsoft® Windows Vista®, Microsoft® Windows® 7: 1 GB or more
Network function	10BASE-T or 100BASE-TX
Image display function	Resolution: 1024 × 768 pixels or more Color generation: True Color (24 bits or more)
Supported operating system	Microsoft® Windows® XP, Microsoft® Windows Vista®, Microsoft® Windows® 7
Hard disk drive	At least 50 MB of free memory
Other	CD-ROM drive (for using the Operating Instructions and various software) Adobe® Reader® (for browsing the Operating Instructions on the CD-ROM)

Installation precautions

● In addition to heeding the points presented in the “Safety precautions”, observe the following precautions as well.

Be absolutely sure to ask your dealer to do the jobs of installing and connecting the unit.

Connecting the power supply

- Use within AC 100 V to 120 V.
- Be absolutely sure to use only the power cable and AC adapter supplied with the unit.
- The power cable supplied with the unit has a 3-pin plug with a grounding terminal. Connect it to a 3-pole outlet which has been connected to ground.
- Be absolutely sure to connect the ground terminal (SIGNAL GND) at the rear of the unit to the system ground.
- When the unit is not going to be used for a prolonged period of time, turn off its power, and disconnect the power plug from the AC outlet.
- To prevent the DC plug from being disconnected, secure the cable of the AC adapter to the cable clamp.

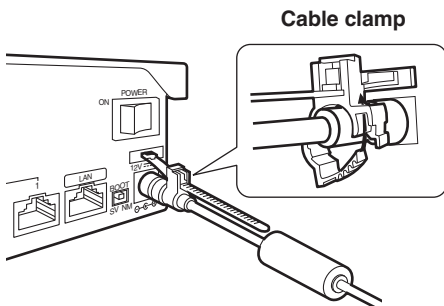

● How to secure the DC plug (side view)

- ① Loosely secure the cable clamp.

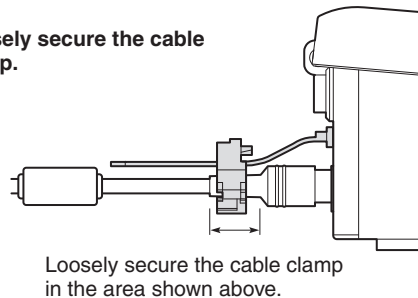

- ② Fasten the cable clamp.

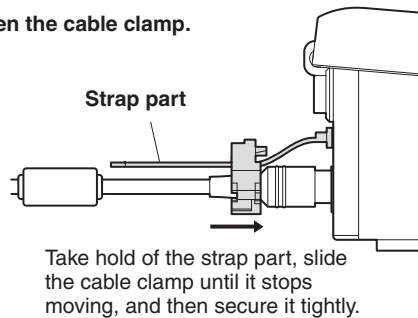

Installation precautions

Handle carefully!

- Dropping the unit or subjecting it to strong impact or vibration may cause trouble and/or malfunctioning.

Do not allow any foreign objects to enter inside the unit!

- Allowing water, metal items, scraps of food or other foreign objects inside the unit may cause a fire and/or electric shocks.

Choosing the best installation location

- This unit is designed for indoor use only.
- Install the unit on a sufficiently strong, stable and level surface for use.
- Ensure a space of at least 100 mm (3-15/16") around the front vents to avoid obstructing ventilation. In particular, ensure sufficient space between ventilation and wiring when using mounted in a panel or table.
- Do not install the unit in a manner in which its cables and other accessories can be easily damaged.
- Do not install the unit in a cold place where the temperatures will drop below 0 °C (32 °F) or in a hot place where the temperatures will rise above +40 °C (104 °F).
- Avoid installing the unit where it will be exposed to direct sunlight or to the hot air that is blown out from other products.
- Installing the unit in a very humid, dusty or vibration-prone location may give rise to trouble.

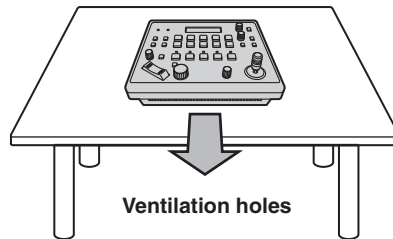

Operating precautions

- In addition to heeding the points presented in the “Safety precautions”, observe the following precautions as well.

Handle carefully.

Do not drop the product, or subject it to strong shock or vibration.

Do not carry or move the product by the PAN/TILT lever.

This is important to prevent trouble.

Use the product in an ambient temperature of 0 °C to +40 °C (32 °F to 104 °F).

Avoid using the product at a cold place below 0 °C (32 °F) or at a hot place above +40 °C (104 °F) because extremely low or high temperature will adversely affect the parts inside.

Power off before connecting or disconnecting cables.

Before plugging or unplugging the cables, be sure to switch power off.

Avoid humidity and dust.

Avoid using the product at a humid, dusty place because much humidity and dust will cause damage to the parts inside.

Maintenance

Wipe the product using a dry cloth. To remove stubborn dirt, dip a cloth into a diluted solution of kitchen detergent (neutral), wring it out well, and wipe the product gently.

Then, after wiping the product with a moist cloth, wipe it again with a dry cloth.

Caution

- Avoid using benzene, paint thinners and other volatile fluids.
- If a chemical cleaning cloth is to be used, carefully read through the precautions for its use.

When the product is to be discarded

When the product is to be discarded at the end of its service life, ask a specialized contractor to dispose of it properly in order to protect the environment.

Concerning the consumable parts

- AC adapter:
This is a consumable part.
As a general rule, replace it every 5 years or so (when the unit has been operated for 15 hours a day).

The period when the consumable parts need to be replaced will differ depending on the operating conditions.

When the time comes to replace one of these parts, be absolutely sure to ask your dealer to do the job.

Parts and their functions

Control panel

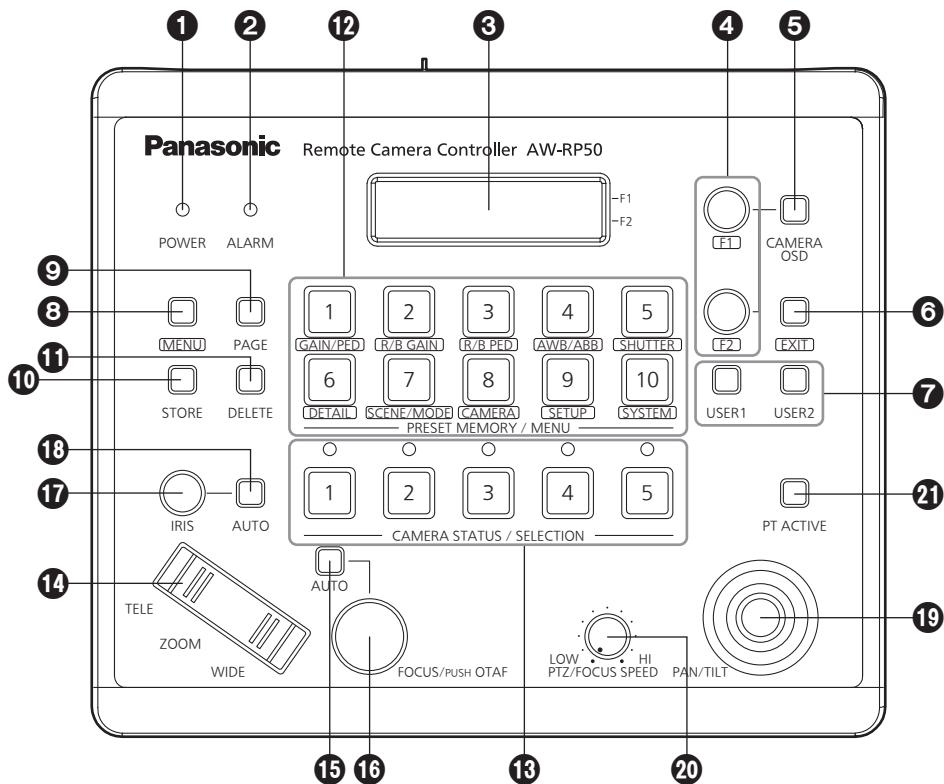

1 POWER indicator [POWER]

This indicator lights when the POWER switch (22) on the rear panel is set to ON while power is supplied to the DC IN socket.

2 ALARM indicator [ALARM]

This indicator lights when there is a problem with the power supply (voltage drop). It also lights when an alarm (a cooling fan alarm or pan/tilt error) has been received from a remote camera.

☞ Refer to “Checking the equipment alarm information” (<Operations and Settings> Operating Instructions).

When the alarm indicator has lighted, stop using the unit immediately, and be absolutely sure to contact your dealer.

Continuing to use the unit even after an alarm has occurred may cause the unit to malfunction.

The alarm information can be output to an external device from the unit’s TALLY/GPI connector (25).

3 LCD panel

The current setting statuses are displayed on this panel.

4 F1 dial, F2 dial [F1, F2]

These dials are turned to change the menu values, and they are pressed to enter the changes that have been made.

The F1 dial is used to operate the items displayed at the top of the LCD panel, and the F2 dial is used to operate the items displayed underneath.

What appears on the on-screen displays of the remote cameras and how operations are performed differ depending on the camera type.

☞ Refer to “Operating the menu items of the selected remote camera” (<Operations and Settings> Operating Instructions).

5 CAMERA OSD button [CAMERA OSD]

When the CAMERA OSD button is held down, its indicator lights, and the on-screen menu of the selected remote camera is displayed as the output image of the remote camera.

When the button is held down again while its indicator is lighted, the menu is cleared, and the indicator goes off.

Parts and their functions

⑥ EXIT button [EXIT]

Press this during menu operations to return to the previous hierarchical level.

⑦ USER buttons [USER1, USER2]

The functions of some of the setting items on the menus can be assigned to [USER1] and [USER2] to be recalled later.

☞ Refer to “Setting the USER buttons” (<Operations and Settings> Operating Instructions).

⑧ MENU button [MENU]

Press this to recall the menus using the PRESET MEMORY/MENU buttons (⑫).

When it is pressed again while its indicator is lighted, the menu is cleared, and the indicator goes off.

Button indicator ON:

The menu operations take effect.

Button indicator OFF:

The menu operations have no effect.

☞ Refer to “Basic operations for the menus”.

⑨ PAGE button [PAGE]

Press this to specify the preset memory of the remote camera.

When the button is pressed, its indicator lights, and the mode for selecting the page of the preset memory is established.

In this mode, press one of the PRESET MEMORY/MENU buttons (⑫), and specify the page number. Next, specify the number on the page using one of the PRESET MEMORY/MENU buttons.

☞ Refer to “Setting and operating the preset memories” (<Operations and Settings> Operating Instructions).

⑩ STORE button [STORE]

Press this to register the preset memory data of the currently selected remote camera.

When it is pressed again while its indicator is lighted, the menu is cleared, and the indicator goes off.

Button indicator ON:

The preset memory data registration mode is established.

Button indicator OFF:

The preset memory data registration mode is released.

☞ Refer to “Setting and operating the preset memories” (<Operations and Settings> Operating Instructions).

⑪ DELETE button [DELETE]

Press this to delete the preset memory data for the currently selected remote camera.

When it is pressed again while its indicator is lighted, the menu is cleared, and the indicator goes off.

Button indicator ON:

The preset memory data deletion mode is established.

Button indicator OFF:

The preset memory data deletion mode is released.

☞ Refer to “Setting and operating the preset memories” (<Operations and Settings> Operating Instructions).

⑫ PRESET MEMORY/MENU buttons [PRESET MEMORY/MENU]

Use these buttons to recall the preset memory data and recall menus.

⑬ CAMERA STATUS/SELECTION buttons [CAMERA STATUS/SELECTION]

Use these buttons to select up to five remote cameras.

Button indicator ON:

The corresponding remote camera is selected.

Button indicator OFF:

The selection of the corresponding remote camera is released.

Using the menu, up to 100 remote cameras can be divided into 1 to 20 groups, and then registered and controlled. The statuses of the remote cameras assigned to buttons 1 to 5 can be identified using the indicators positioned above the buttons.

☞ Refer to “Selecting the remote cameras to be operated”.

⑭ ZOOM button [ZOOM]

Use this to adjust the lens zoom.

When the TELE end is pressed:

Telephoto setting

When the WIDE end is pressed:

Wide-angle setting

The zooming speed changes depending on the extent to which the button is pressed.

Parts and their functions

15 Auto focus button [AUTO]

Press this to control the focus automatically.

Button indicator ON:

Auto focusing

Button indicator OFF:

Manual focusing

During auto focusing, operating the FOCUS/PUSH OTAF dial (16) will have no effect.

- This function works when an auto focus function is provided in the remote cameras.
If the auto focus function is not provided, operate the focus manually (in which case the button indicator will be OFF).

16 FOCUS/PUSH OTAF dial [FOCUS/PUSH OTAF]

Use this to control the focus manually.

When it is turned clockwise:

The focusing moves to the far end.

When it is turned counterclockwise:

The focusing moves to the near end.

When the dial is pressed, auto focusing is initiated temporarily, and the subject being shot is brought into focus. (OTAF)

During auto focusing (while the indicator of the auto focus button (15) is lighted), operating this dial will have no effect.

OTAF: one-touch auto focus

17 IRIS dial [IRIS]

Use this dial to control the lens iris manually.

When it is turned clockwise:

The lens iris opens more and more.

When it is turned counterclockwise:

The lens iris closes more and more.

When it is held down:

The lens iris closes.

During auto iris (while the indicator of the auto iris button (18) is lighted), operating this dial will have no effect.

18 Auto iris button [AUTO]

Press this to control the lens iris automatically.

Button indicator ON:

Auto iris

Button indicator OFF:

Manual iris

During auto iris, operating the iris dial (17) will have no effect.

19 PAN/TILT lever [PAN/TILT]

Use this lever to control the direction of the remote cameras.

When it is leaned toward the left or right:

The cameras move to the left or right.

When it is leaned toward you or away from you:

The cameras move up or down.

The movement speed differs depending on the angle to which the lever is moved.

20 PTZ/FOCUS SPEED dial [PTZ/FOCUS SPEED]

Use this dial to adjust the speed at which the operations (pan, tilt, zoom, focus) of the remote cameras are controlled.

When it is turned clockwise:

Operation at a higher speed

When it is turned counterclockwise:

Operation at a lower speed

21 PT ACTIVE button [PT ACTIVE]

Press this to switch between enabling and disabling the PAN/TILT lever operations.

Button indicator ON:

The PAN/TILT lever operations take effect.

Button indicator OFF:

The PAN/TILT lever operations have no effect.

Parts and their functions

■ Rear panel

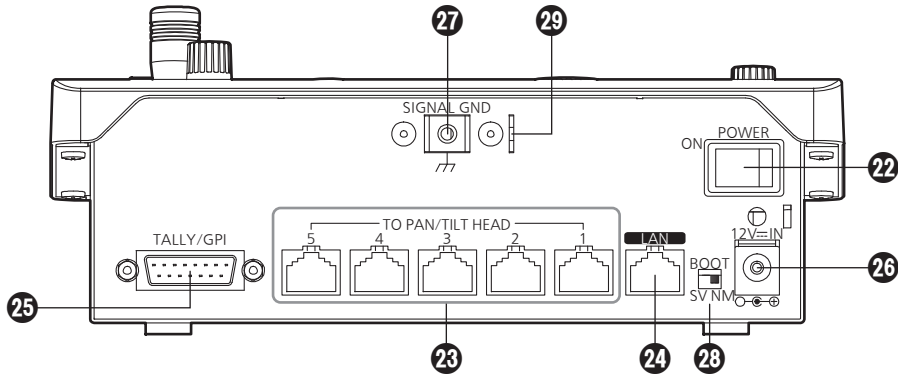

22 POWER switch [POWER]

When the POWER switch is set to the ON position, the POWER indicator (●) lights, and the unit can be operated.

23 TO PAN/TILT HEAD 1 to 5 connectors [TO PAN/TILT HEAD 1 to 5] (RJ-45)

Connect the remote cameras to these connectors using straight cables (category 5 or above).

24 LAN connector [LAN] (RJ-45) (10BASE-T/100BASE-TX)

Connect the remote camera, switcher or host computer that supports IP connections to this connector using a LAN cable.

When directly connecting a device to the unit, use a crossover cable (category 5 or above).

When making the connection through a hub (switching hub) or other device, use a straight cable (category 5 or above).

25 TALLY/GPI input/output connector [TALLY/GPI]

(D-sub 15-pin, female, inch thread)

☞ Refer to “Control interface for external devices” (<Operations and Settings> Operating Instructions).

26 DC IN socket [12V IN] (DC 12 V)

The AC adapter provided with the unit is connected to this socket.

27 Ground terminal [SIGNAL GND]

Connect this to the system's ground.

28 SERVICE switch [SV/NM]

This switch is used for maintenance purposes. Normally, it is set at the “NM” position.

29 Wire fastening fitting

An anti-theft wire available on the market can be fastened to this fitting to prevent theft.

Basic operations of the unit

1 Turn on the unit's power.

Set the POWER switch to the ON position. Power is now supplied to the unit, and the POWER indicator lights.

- However, when [CAMERA] → [POWER] → AUTO ON item have been selected and "On" is selected as the AUTO ON item setting, power-on is automatically instructed for the remote cameras controlled by the [SYSTEM] → CAM IP ADR item.

2 Select the remote cameras.

Select the remote cameras to be controlled using the CAMERA STATUS/SELECTION buttons.

3 Adjust the direction in which the remote cameras are to be pointed.

Use the PAN/TILT lever to adjust the direction in which the remote cameras are to be pointed.

4 Adjust the zoom.

Use the ZOOM button to adjust the lens zoom. When the TELE side is pressed, the zoom is set to the telephoto mode; when the WIDE side is pressed, it is set to the wide-angle mode.

5 Adjust the lens iris.

Use the IRIS dial to adjust the lens iris.

- While the lens iris is being adjusted, a level meter is displayed on the LCD panel. (What is displayed by the level meter is an approximate value.)

IRIS

--*-----+

Note

When performing adjustments for one remote camera from a multiple number of AW-RP50 remote camera controllers, the level meter may not show the correct displays.

6 Adjust the focus.

Turn the FOCUS/PUSH OTAF dial, and adjust the lens focus.

When the dial is pressed during manual focusing, the auto focus mode is established temporarily, and the subject is brought into focus automatically.

- The OTAF (one-touch auto focus) takes effect for remote cameras which are equipped with the OTAF function.

7 Turn off the unit's power.

Set the POWER switch to the OFF position.

The unit's power is turned off, and the POWER indicator goes off.

- Even when the unit's power is turned off, the power of the connected remote cameras does not go off.

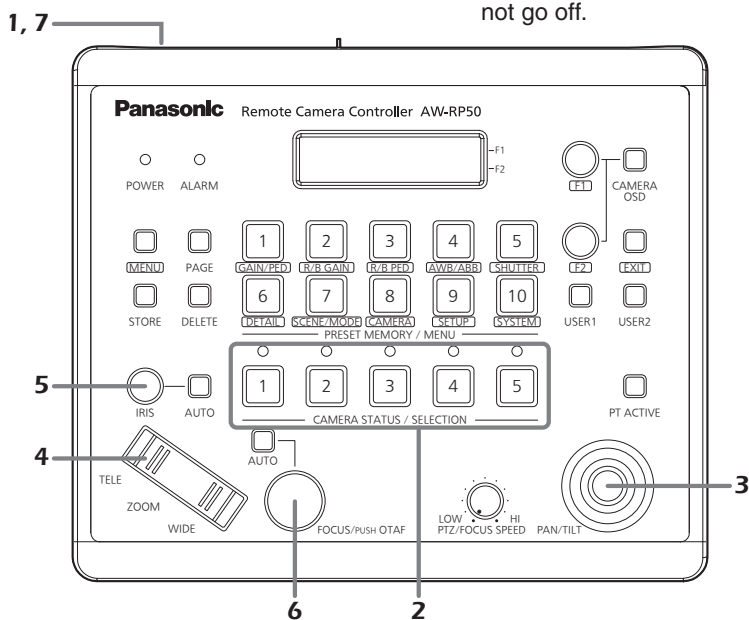

For detailed operations, refer to the Operating Instructions — <Operations and Settings>.

Basic operations for the menus

1 Set the MENU button to ON.

Press the MENU button and light its indicator.

2 Select the target menu.

Press the corresponding PRESET MEMORY/MENU button, and light its indicator.

For details on the menus assigned to these buttons, refer to "Table of menu items" (<Operations and Settings> Operating Instructions).

The selected menu is displayed on the LCD panel.

3 Change the settings using the F1 dial and F2 dial.

Use the F1 dial and F2 dial to select the menus and change the settings.

Use the F1 dial for operations involving the items displayed on the top line of the LCD panel.

Use the F2 dial for operations involving the items displayed on the bottom line of the LCD panel.

- Press the EXIT button to return the menu to its previous hierarchical level.
- When the down arrow "↓" is displayed for a setting item, it means that the value shown will be entered and the setting reflected when the F1 dial or F2 dial is pressed.

1.GROUP SELECT



- When the down arrow "↓" is not displayed for a setting item, it means that the value shown will be entered and the setting reflected when the F1 dial or F2 dial is turned.

RGAIN : ±0 ← F1 dial
BGAIN : ±0 ← F2 dial

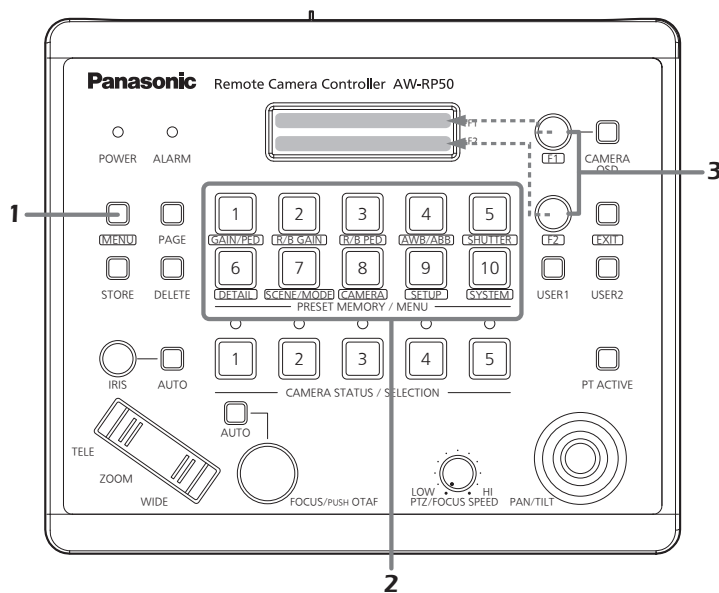

For detailed operations, refer to the Operating Instructions — <Operations and Settings>.

Network settings

This section describes how the unit's network are set.

Note

Correct operation is not possible if the same IP address already exists in the same network. Set the IP addresses in such a way that they do not duplicate any existing IP addresses.

Setting the unit

The unit's settings are established using the [SYSTEM] menu. Set the IP address, subnet mask and default gateway. First, the basic menu operations will be described.

1 Set the MENU button to ON.

Press the MENU button, and light its indicator.

2 Set the PRESET MEMORY/MENU 10 button (SYSTEM) to ON.

When the button is pressed and its indicator is lighted, the [SYSTEM] menu is displayed on the LCD panel.

[1]CAMERA CTL ▼

3 Turn the F1 dial, and display the [NETWORK] menu.

[6]NETWORK ◆

4 Press the F1 dial.

1. IP ADDRESS ▼
192↓168.000.009

5 Turn the F1 dial, and display the target setting item.

1. IP ADDRESS ▼
192↓168.000.009



2. SUBNETMASK ◆
255↓255.255.000



3. GATEWAY ◆
192↓168.000.001



4. MAC ADDRESS ▲

6 Turn the F2 dial, and select the setting.

2. SUBNETMASK ◆
255↓255.255.000

7 Press the F2 dial, and change the setting.

2. SUBNETMASK ◆
255.255↓255.000

Input all the settings except for the MAC address in four blocks of numerals. When input advances to the last block and the F2 dial is pressed, the IP address is entered.

2. SUBNETMASK ◆
255.255.255.000↓

- The MAC address is merely displayed — it cannot be changed.

Note

In order for the settings to take effect, the unit must be restarted. Turn off the unit's power, and then turn it back on again.

Network settings

Setting the IP address

On the [SYSTEM] menu, select the [NETWORK] menu, and display [IP ADDRESS]. Then operate the F2 dial to set the IP address. Select a setting which will not duplicate the IP setting of another device.

1. IP ADDRESS ▼
192↓168.000.009

If the same IP address is used more than once, the "IP Duplicate!" message is displayed on the LCD panel.

1. IP ADDRESS ▼
IP Duplicate!

If the IP address is incorrect, the following message is displayed on the LCD panel.

Unavailable
network setting

Notes

- In order for the setting to take effect, the unit must be restarted. Turn off the unit's power, and then turn it back on again.
- Consult the network administrator before setting the IP address.

Setting the subnet mask

On the [SYSTEM] menu, select the [NETWORK] menu, and display [SUBNETMASK]. Then operate the F2 dial to set the subnet mask.

2. SUBNETMASK ◆
255↓255.255.000

If the subnet mask is incorrect, the following message is displayed on the LCD panel.

Unavailable
network setting

Note

In order for the setting to take effect, the unit must be restarted. Turn off the unit's power, and then turn it back on again.

Setting the default gateway

On the [SYSTEM] menu, select the [NETWORK] menu, and display [GATEWAY]. Then operate the F2 dial to set the gateway.

3. GATEWAY ◆
192↓168.000.001

If the default gateway is incorrect, the following message is displayed on the LCD panel.

Unavailable
network setting

Note

In order for the setting to take effect, the unit must be restarted. Turn off the unit's power, and then turn it back on again.

Network settings

Setting the port number

Set the port number for the remote camera.
On the [SYSTEM] menu, select [CAM PORT] and display [PORT:CAM1] to [PORT:CAM100], and then operate the F2 dial to set the port number.

1. PORT:CAM1 ▼
80↓

Setting the MAC address

On the [SYSTEM] menu, select the [NETWORK] menu, and display [MAC ADDRESS].

4. MAC ADDRESS ▲

Connections

■ Example of IP connections

● Connections with the AW-HE50 and AW-HS50

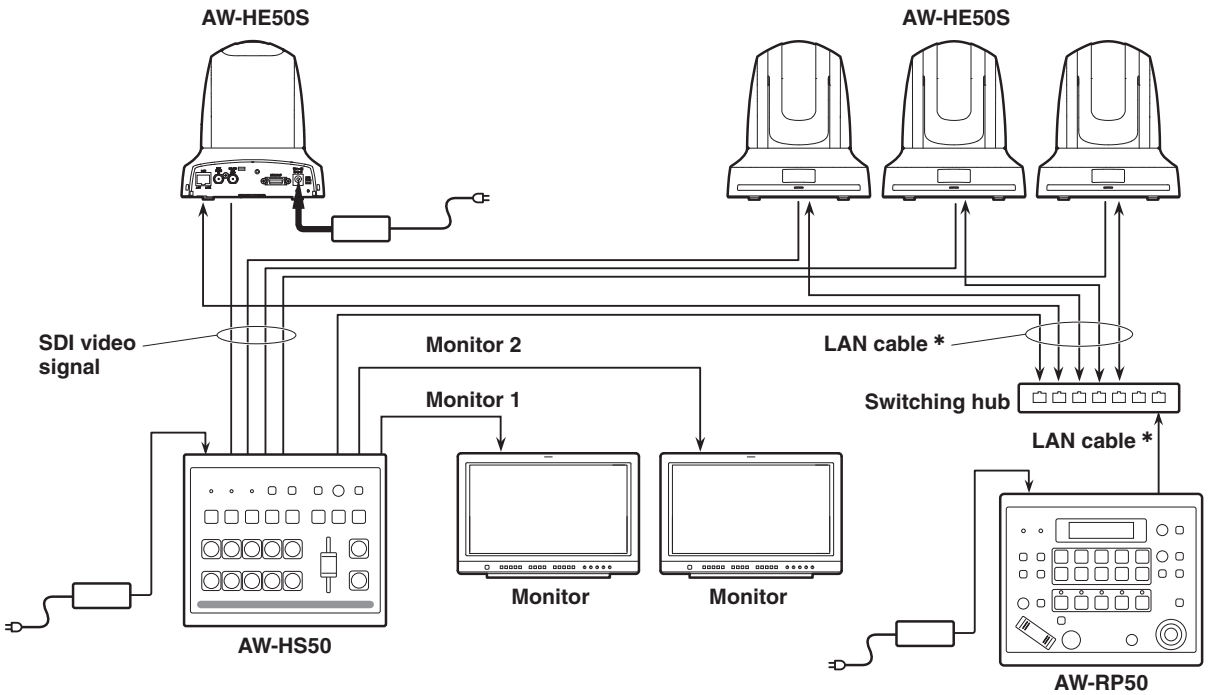

● Connecting a multiple number of the units with the AW-HE50 units

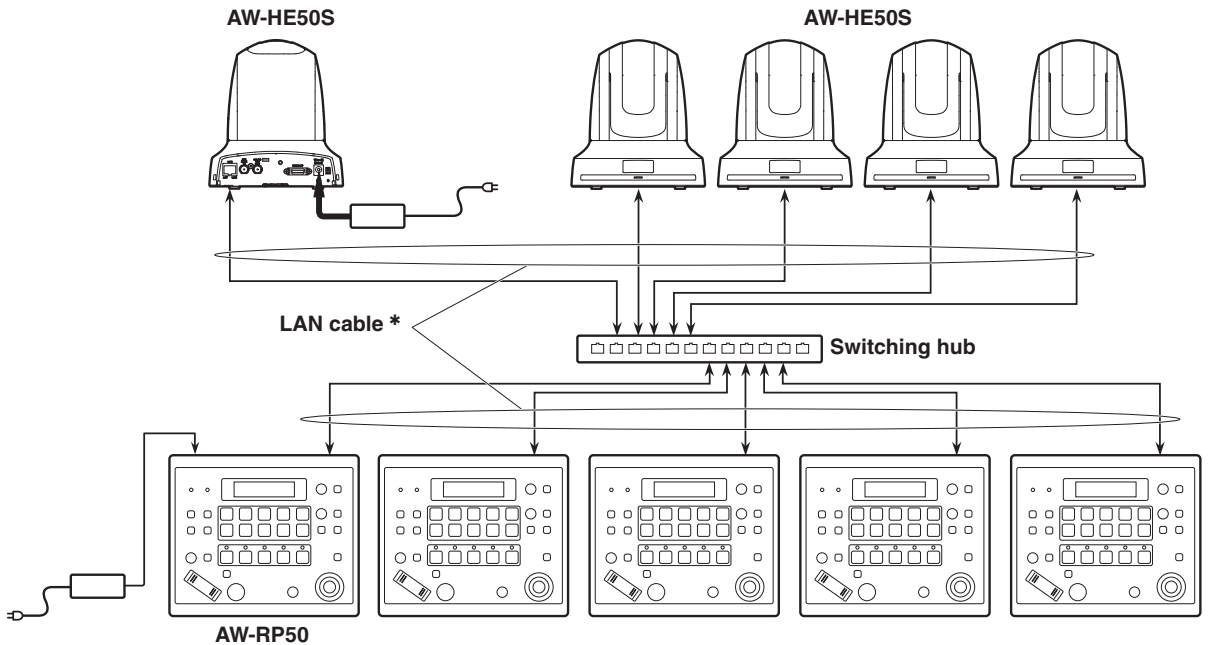

*: Use straight cables (category 5 or above) for these connections.

Connections

■ Example of serial connections

● Connection with the AW-HE50

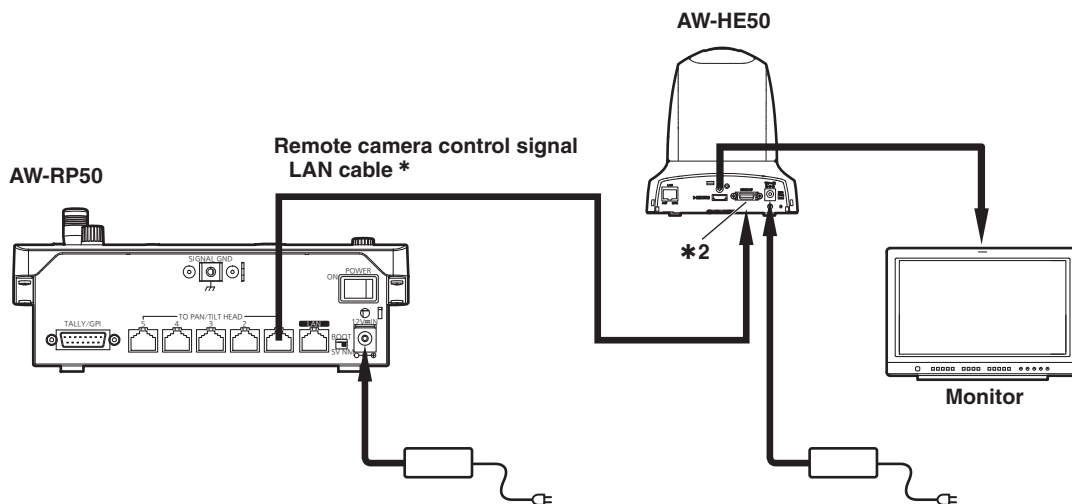

- *1: Use straight cables (category 5 or above) for these connections.
- *2: The multi-interface cable (AW-CA20T6G) is required for the serial connection with the AW-HE50.

● Connection with the AW-HE100

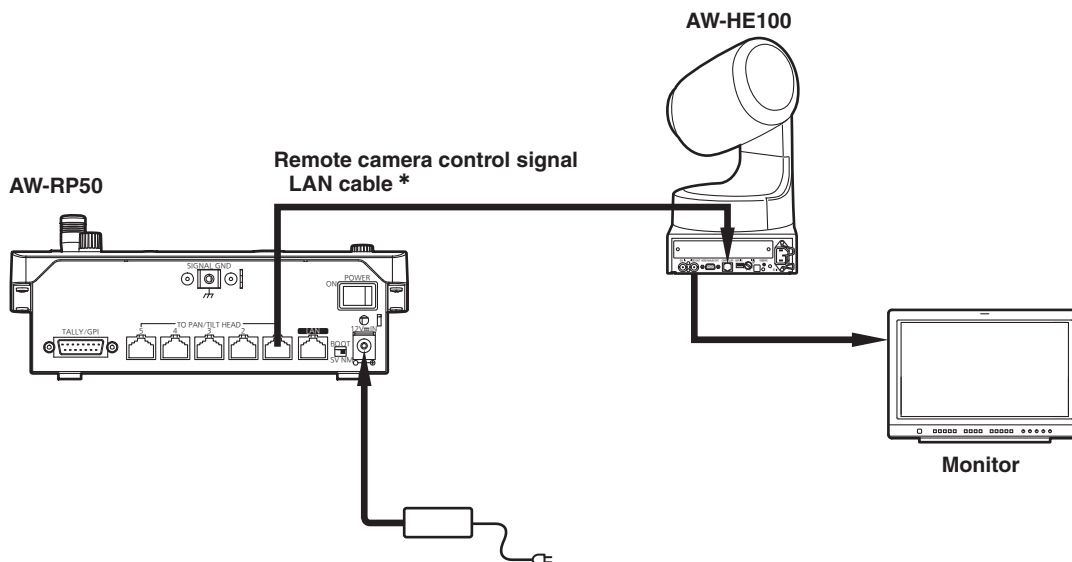

- *: Use straight cables (category 5 or above) for these connections.

Connections

● Connections with the AW-PH400 and camera

Camera model:
AW-HE870, AW-E860, AW-E750, AW-E650, AW-E350, AK-HC1500 or AK-HC1800

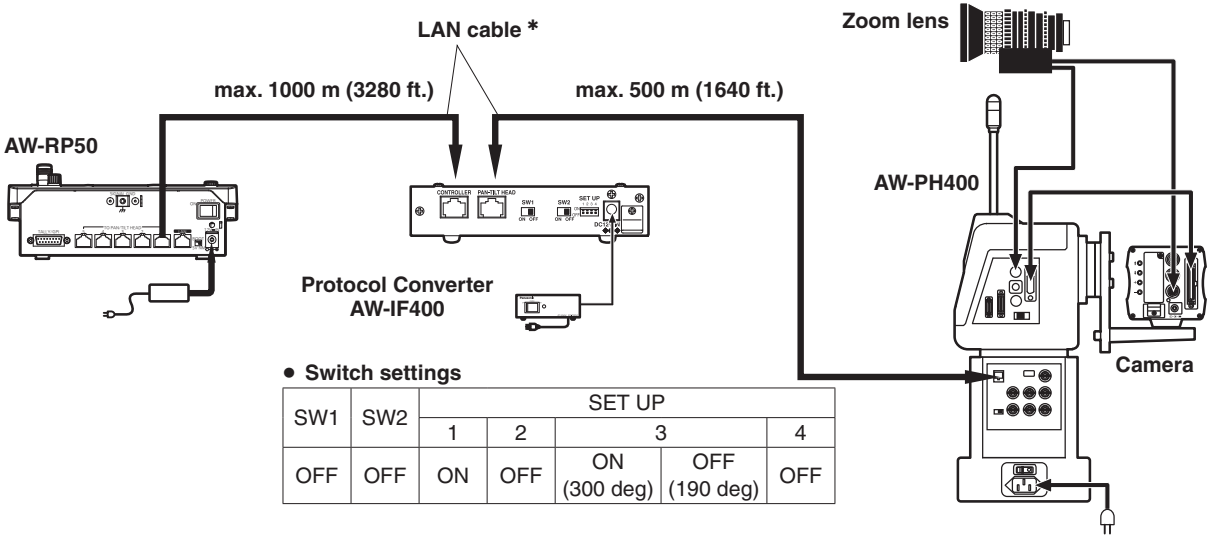

● Connections with the AW-PH405 and camera

Camera model:
AW-HE870, AW-E860, AW-E750, AW-E650, AW-E350, AK-HC1500 or AK-HC1800

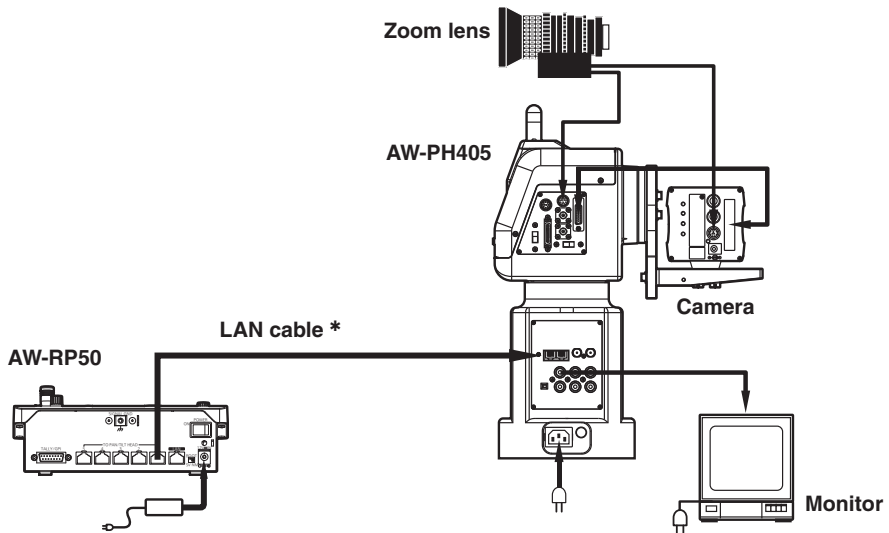

*: Use straight cables (category 5 or above) for these connections.

Connections

● Connection with the AW-PH650

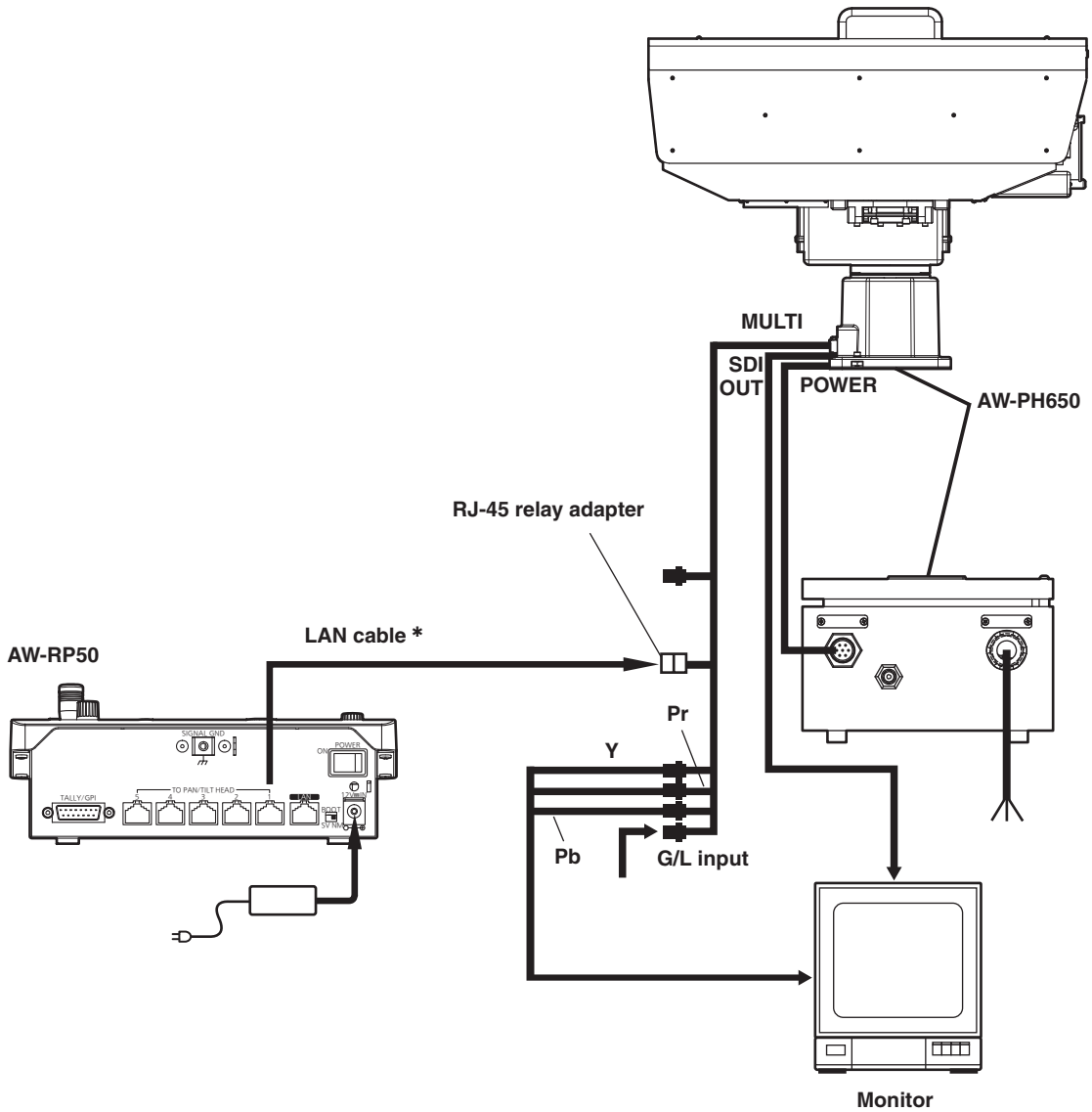

*: Use straight cables (category 5 or above) for these connections.

Connections

There are two procedures for the connection settings, and these are described in “Settings for connection with the remote cameras” and “Settings for connection with the switcher”.

There are two series of steps to be taken for “Settings for connection with the remote cameras”.

- Setting method using the unit (Refer to the following items.)
 - ☞ “Settings for connection with the remote cameras”
 - ☞ “Setting the IP addresses automatically (auto IP setting)”
 - ☞ “Changing the IP addresses of the camera numbers controlled by the unit”
 - ☞ “Changing the camera numbers”
- Setting method using the “Setup Software”
 - ☞ Refer to “Setup Software” (<Operations and Settings> Operating Instructions). The “Setup Software” is provided on the supplied CD-ROM.

The “Settings for connection with the switcher” are established using the unit.

- ☞ Refer to “Setting linkup with the switcher” (<Operations and Settings> Operating Instructions).

If the same information on the settings for the connections with the remote cameras is shared among a multiple number (up to 5 units) of AW-RP50 remote camera controllers which are connected on the same network, the operations are performed using the “Setup Software” provided on the supplied CD-ROM.

- ☞ Refer to “Saving and loading data” in the “Setup Software” section of the (<Operations and Settings> Operating Instructions).

■ Settings for connection with the remote cameras

Either serial connection “Serial” or IP connection “Network” can be selected for the connections between the unit and the remote cameras for camera numbers CAM1 to CAM100.

On the [SYSTEM] menu, select [CAMERA CTL], and display [CAM1] to [CAM100].

Then select the setting for the camera numbers.

Serial: Serial connection

Network: IP connection

NoAssign: No setting assigned (initial setting)

● Serial connection

Select “Serial” as the setting for the target camera number.

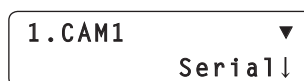

Camera numbers CAM1 to CAM5 correspond to the TO PAN/TILT HEAD connectors [1] to [5] on the unit's rear panel.

- Serial connection “Serial” cannot be selected for camera numbers CAM6 to CAM100.

● IP connection

Select “Network” as the setting for the target camera number.

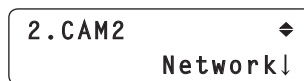

On the [SYSTEM] menu, select [CAM IP ADR], and display [IP:CAM1] to [IP:CAM100]. Then use the IP addresses corresponding to the camera numbers for the connection.

Note

When performing the steps described in “Auto IP setting”, set “NoAssign” for the target camera number.

Connections

■ Setting the IP addresses automatically (auto IP setting)

When “Auto IP setting” is initiated, the IP addresses are set automatically for the remote cameras and the switcher which are connected within the same subnet. The IP addresses can be set for up to 100 remote cameras and one switcher.

[Remote camera settings]

The unit sets the IP addresses for the remote cameras that have been detected by associating them with **camera numbers whose connection setting is set to “NoAssign”**.

Connection settings:

On the [SYSTEM] menu, select [CAMERA CTL], and then display items [CAM1] to [CAM100].

Setting or changing IP addresses:

On the [SYSTEM] menu, select [CAM IP ADR], and then display items [CAM1] to [CAM100].

Example:

- ① Remote cameras A, B, and C are detected.
- ② In [CAMERA CTL], items [CAM1] to [CAM3] are all set to “NoAssign”.
- ③ In [CAM IP ADR], the IP addresses of items [CAM1] to [CAM3] range from 192.168.000.010 to 192.168.000.012.

In the above example, the IP addresses for the remote cameras are set as follows:

Remote camera A: 192.168.000.010
Remote camera B: 192.168.000.011
Remote camera C: 192.168.000.012

- Subnet mask, default gateway, and port number settings are the same as those for the unit.
- The connection setting for camera numbers that have been set once with “Auto IP setting” becomes “Network”.

These camera numbers will be excluded as targets of “Auto IP setting” the next time that “Auto IP setting” is performed.

However, if the IP address for a camera number that has been set with “Auto IP setting” is changed, or if a camera number’s connection setting is changed to “NoAssign” or “Serial”, the corresponding camera numbers will be targeted in the next “Auto IP setting” operation.

- If the IP address for a detected remote camera matches the IP address set for a camera number (a camera number with a connection setting other than “Serial”), the IP address setting for the remote camera will be used as is. If the IP address for a remote camera is set once and then changed so that it differs from the IP address set for the camera number, the remote camera IP address is set again to the camera number IP address.

[Switcher settings]

The IP address set in the [IP:SW] item from [SW IP ADR] on the [SYSTEM] menu will be set for the switcher.

Notes

- Duplication in the IP addresses may arise when a device other than a remote camera or switcher has been connected within the same subnet. Connect only devices which are covered by the “Auto IP setting” within the same subnet.
- If a remote camera with the same IP address as the unit’s exists, the IP address of the remote camera concerned cannot be set by following the steps in “Auto IP setting”.
- When a multiple number of AW-RP50 remote camera controllers have been connected in the same subnet, do not perform the steps described in “Auto IP setting” using each controller at the same time.
- When the steps described in “Auto IP setting” have been performed by operating the unit, do not use the “Setup Software” (provided with the unit) in the host computer end at the same time. Similarly, do not use the “Easy IP Setup Software” provided with the AW-HE50 at the same time. Otherwise, the settings may not be established correctly.

Connections

● When setting the IP addresses for the first time

The IP addresses are set while the remote cameras, switcher and unit are at their factory settings.

Note

Before setting the IP addresses, check that “NoAssign” is shown as the remote camera’s connection setting.

Connection settings:

On the [SYSTEM] menu, select [CAMERA CTL], and then display items [CAM1] to [CAM100].

1 Connect the remote cameras, switcher and unit to the network within the same subnet.

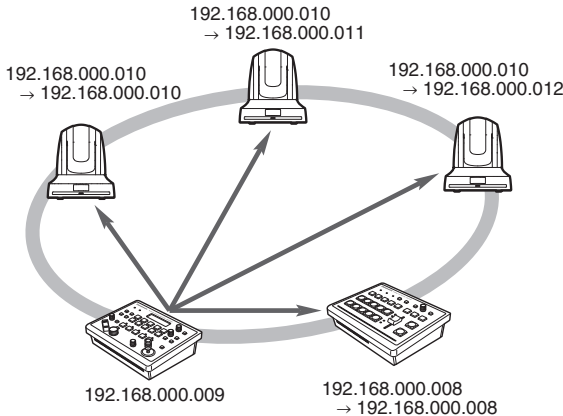

2 On the [SYSTEM] menu, select [AUTO SET IP], and display [AUTO SETUP]. Then select “RENEW IP ADR”, and press the F2 dial.

1. AUTO SETUP
RENEW IP ADR↓

Both the number of devices (all remote cameras and the switcher) currently being managed by the unit and the number of new devices detected are displayed on the LCD panel.

C: 003/003 S: 1/1
YES↓

C: 003/003

Number of devices currently managed by the unit + Number of new devices detected

Number of new devices detected

C: Remote camera, S: Switcher

Memo

- If the number of new devices detected exceeds the number of devices that can be registered (100 remote cameras and 1 switcher), [C/S OVER!] will be displayed at the bottom of the LCD panel. Automatic IP address setting can be performed even in this state, but IP addresses will be set only for the number of devices that can be registered.

C: 020/100 S: 1/1
C/S OVER! YES↓

- When a multiple number of remote cameras have been started up at the same time, for instance, it may not be possible for all of these cameras to be detected by the unit. In this case, select “RETRY”, and then press the F2 dial to retry the operation. The number of units to be added can be updated.

- The number displayed for “Number of new devices detected” may be lower than the actual number of devices to be set, due to a cause such as the remote cameras or switches not being powered on. In this case, eliminate the cause of the problem, select “RETRY”, and then press the F2 dial to retry the operation. The number of units to be added can be updated.

C: 020/020 S: 1/1
RETRY↓

Connections

3 Turn the F2 dial, select “Yes”, and then press the F2 dial.

This starts the “Auto IP setting” process. When “Auto IP setting” has been initiated, the progress is shown by the number of displayed dots which are reduced one by one.



AUTO SETUP
.....

When all the operations have been completed successfully, “COMPLETE!” is displayed.



AUTO SETUP
COMPLETE!

The remote cameras and the switcher are automatically rebooted, and they restart with the new IP addresses which were set.

The remote cameras can now be operated from the unit.

The function for linking the switcher with the unit becomes available for use at this point.

Memo

If the IP addresses were not set successfully, “SET UP ERR!” is displayed.



AUTO SETUP
SET UP ERR!

The cause of the problem is likely a network malfunction.

Check the connection status of the hub and LAN cables, and then retry the “Auto IP setting” operation.

Connections

● When introducing additional remote cameras or a switcher into an environment where similar existing devices are already in use

Even when additional remote cameras or switcher are introduced into an environment where similar existing devices are already in use, the settings can be easily established using “Auto IP setting”.

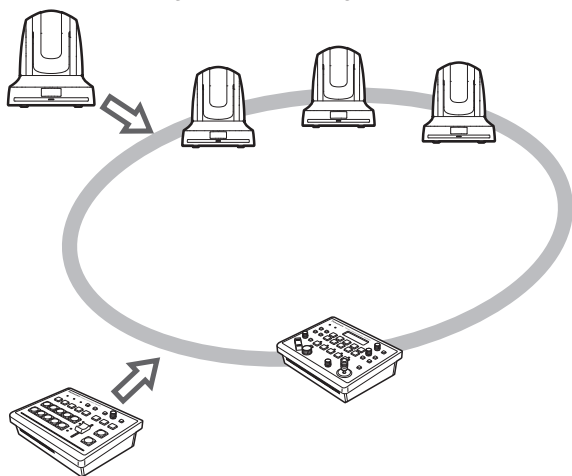

There are two methods for setting the IP addresses of newly introduced devices (remote cameras or a switcher), as follows:

1. **Setting the IP address from the unit**
2. **Changing the IP address on the unit to match the IP address of the remote camera or switcher**

This section explains each of these methods.

■ Setting the IP address from the unit

[Remote camera settings]

The unit sets the IP addresses for the remote cameras that have been detected by associating them with camera numbers whose connection setting is set to “NoAssign”.

Connection settings:

On the [SYSTEM] menu, select [CAMERA CTL], and then display items [CAM1] to [CAM100].

Setting or changing IP addresses:

On the [SYSTEM] menu, select [CAM IP ADR], and then display items [CAM1] to [CAM100].

Example:

- ① Three remote cameras are in operation.
- ② An additional remote camera is newly introduced (and becomes remote camera D).
- ③ Remote camera D is detected.
- ④ In [CAMERA CTL], the [CAM4] item is set to “NoAssign”.
- ⑤ In [CAM IP ADR], the IP address for the [CAM4] item is 192.168.000.013.

In the above example, remote camera D's camera number allocation becomes CAM4, and its IP address is set as follows:

Remote camera D: 192.168.000.013

- Subnet mask, default gateway, and port number settings are the same as those for the unit.

[Switcher settings]

The IP address set in the [IP:SW] item from [SW IP ADR] on the [SYSTEM] menu will be set for the switcher.

Connections

1 Connect the additional remote cameras and the switcher to be introduced and the unit to the network within the same subnet.

2 On the [SYSTEM] menu, select [AUTO SET IP], and display [AUTO SETUP]. Then select “RENEW IP ADR”, and press the F2 dial.

1. AUTO SETUP
RENEW IP ADR↓

Both the number of devices (all remote cameras and the switcher) currently being managed by the unit and the number of new devices detected are displayed on the LCD panel.

C : 001 / 004 S : 0 / 1
YES↓

C : 001 / 004

Number of devices currently managed by the unit + Number of new devices detected

Number of new devices detected

C: Remote camera, S: Switcher

Memo

- If the number of new devices detected exceeds the number of devices that can be registered (100 remote cameras and 1 switcher), [C/S OVER!] will be displayed at the bottom of the LCD panel. Automatic IP address setting can be performed even in this state, but IP addresses will be set only for the number of devices that can be registered.

C : 020 / 100 S : 1 / 1
C/S OVER! YES↓

- The number displayed for “Number of new devices detected” may be lower than the actual number of devices to be set, due to a cause such as the remote cameras or switches not being powered on. In this case, eliminate the cause of the problem, select “RETRY”, and then press the F2 dial to retry the operation.

The number of units to be added can be updated.

C : 020 / 020 S : 1 / 1
RETRY↓

3 Turn the F2 dial, select “Yes”, and then press the F2 dial.

This starts the “Auto IP setting” process. When “Auto IP setting” has been initiated, the progress is shown by the number of displayed dots which are reduced one by one.

AUTO SETUP
.....

When all the operations have been completed successfully, “COMPLETE!” is displayed.

AUTO SETUP
COMPLETE!

The remote cameras and the switcher are automatically rebooted, and they restart with the new IP addresses which were set. The remote cameras can now be operated from the unit. The function for linking the switcher with the unit becomes available for use at this point.

Memo

If the IP addresses were not set successfully, “SET UP ERR!” is displayed.

AUTO SETUP
SET UP ERR!

The cause of the problem is likely a network malfunction.

Check the connection status of the hub and LAN cables, and then retry the “Auto IP setting” operation.

Connections

Changing the IP address on the unit to match the IP address of the remote camera or switcher

[Remote camera settings]

The unit sets the IP addresses for the remote cameras that have been detected by associating them with camera numbers whose connection setting is set to “NoAssign”.

Connection settings:

On the [SYSTEM] menu, select [CAMERA CTL], and then display items [CAM1] to [CAM100].

Setting or changing IP addresses:

On the [SYSTEM] menu, select [CAM IP ADR], and then display items [CAM1] to [CAM100].

Example:

- ① Three remote cameras are in operation.
- ② An additional remote camera with an IP address of “192.168.000.020” is newly introduced (and becomes remote camera E).
- ③ Remote camera E is detected.
- ④ In [CAMERA CTL], the [CAM4] item is set to “NoAssign”.

In the above example, on the [SYSTEM] menu, in [CAM IP ADR], the IP address of the [CAM4] item is set to “192.168.000.020”.

- Subnet mask, default gateway, and port number settings are the same as those for the unit.

[Switcher settings]

The IP address for the switcher will be set in the [IP:SW] item from [SW IP ADR] on the [SYSTEM] menu.

Note

If different subnet mask settings are used for unit and remote camera, no operations using the network will be possible.

- 1 Connect the additional remote cameras and the switcher to be introduced and the unit to the network within the same subnet.
- 2 On the [SYSTEM] menu, select [AUTO SET IP], and display [AUTO SETUP]. Then select “KEEP IP ADR”, and press the F2 dial.

1.AUTO SETUP
KEEP IP ADR↓

Both the number of devices (all remote cameras and the switcher) currently being managed by the unit and the number of new devices detected are displayed on the LCD panel.

C:001/004 S:0/1
YES↓

C:001/004

Number of devices currently managed by the unit + Number of new devices detected

Number of new devices detected

C: Remote camera, S: Switcher

Memo

- If the number of new devices detected exceeds the number of devices that can be registered (100 remote cameras and 1 switcher), [C/S OVER!] will be displayed at the bottom of the LCD panel. Automatic IP address setting can be performed even in this state, but IP addresses will be set only for the number of devices that can be registered.

C:020/100 S:1/1
C/S OVER! YES↓

- The number displayed for “Number of new devices detected” may be lower than the actual number of devices to be set, due to a cause such as the remote cameras or switches not being powered on. In this case, eliminate the cause of the problem, select “RETRY”, and then press the F2 dial to retry the operation. The number of units to be added can be updated.

C:020/020 S:1/1
RETRY↓

Connections

3 Turn the F2 dial, select “Yes”, and then press the F2 dial.

This starts the “Auto IP setting” process. When “Auto IP setting” has been initiated, the progress is shown by the number of displayed dots which are reduced one by one.

AUTO SETUP
.....

When all the operations have been completed successfully, “COMPLETE!” is displayed.

AUTO SETUP
COMPLETE!

The remote cameras can now be operated from the unit. The function for linking the switcher with the unit becomes available for use at this point.

Memo

- The “IP Duplication!” message is displayed if there is duplication between the IP addresses of the devices in operation and the IP addresses of the additional remote cameras to be introduced. The IP addresses are not set for those remote cameras whose IP addresses are in duplication.

AUTO SETUP
IP Duplication!

Check the IP addresses, and then retry the “Auto IP setting” operation.

- If the IP addresses were not set successfully, “SET UP ERR!” is displayed.

AUTO SETUP
SET UP ERR!

The cause of the problem is likely a network malfunction. Check the connection status of the hub and LAN cables, and then retry the “Auto IP setting” operation.

Connections

■ Changing the IP addresses of the camera numbers controlled by the unit

Use the steps below when connecting the remote cameras (through a router) whose IP addresses cannot be set by following the steps in “Auto IP setting”.

● Setting the IP addresses

On the [SYSTEM] menu, select [CAM IP ADR], and display [IP:CAM1] to [IP:CAM100]. The IP addresses of the camera numbers can now be changed.

Even when “NoAssign” or “Serial” has been selected as the [CAM1] to [CAM100] setting of [CAMERA CTL] on the [SYSTEM] menu, the IP addresses can still be changed.

1 . IP : CAM1 ▼
192 . 168 . 000 . 100 ↓

The IP addresses are set for all the camera numbers [CAM1] to [CAM100].

Initial values:

CAM1 (192.168.000.010)



CAM100 (192.168.000.109)

Memo

If the unit's IP address has been changed using the [IP ADDRESS] item of [NETWORK] on the [SYSTEM] menu, the IP addresses of the camera numbers which were set to “NoAssign” for the [CAM1] to [CAM100] item of [CAMERA CTL] on the [SYSTEM] menu and which are higher than the unit's IP address, will be automatically re-set in the sequence of the camera numbers set to “NoAssign” starting with the lowest number.

When the IP addresses are changed, a check for IP address duplication is conducted.

A check is carried out to verify whether there is any duplication with the IP addresses of the camera numbers which were set to “Network” for the [CAM1] to [CAM100] item of [CAMERA CTL] on the [SYSTEM] menu.

If duplication is found, the “Duplicate!” is displayed for three seconds, and the IP addresses cannot be set.

1 . IP : CAM1
Duplicate!

Note

The IP addresses set by following these steps are the IP address of the camera numbers controlled by the unit.

The IP addresses of the remote cameras are not changed.

Connections

■ Changing the camera numbers

The camera numbers which have been set by “Auto IP setting” can be changed. They are changed by replacing the IP addresses of the current camera numbers with the IP addresses of the camera numbers to be changed.

1 On the [SYSTEM] menu, select [CAMASSIGN], and display [CAM1] to [CAM100]. Then select the camera number to be changed.

2 Select the IP address of the remote camera for the selected camera number.

The tally indicator of the remote camera corresponding to the selected IP address lights. Operate the PAN/TILT lever, and check whether the camera whose camera number is to be changed is being moved.

The IP address that can be selected is the IP address of the camera number which has been set for “Network” for the [CAM1] to [CAM100] item of [CAMERA CTL] on the [SYSTEM] menu.

3 Press the F2 dial to enter the IP address.

The IP addresses for the camera number of the change destination and for the camera number of the change source are switched over.

1 . CAM1 ▼
192 . 168 . 000 . 100 ↓

Note

When “ASSIGN” is displayed for the [CAM1] to [CAM100] item of [CAM ASSIGN] on the [SYSTEM] menu, the CAMERA STATUS/ SELECTION buttons cannot be operated, and the camera operations (IRIS, FOCUS, PT, ZOOM and CAMERA OSD) cannot be controlled.

■ Changing the IP address of the switcher

The IP address of the switcher which was set by “Auto IP setting” can be changed.

1 On the [SYSTEM] menu, select [SW IP ADR], and display [IP:SW]. Then change the IP address.

■ Clearing the IP address control tables

All the IP address control tables which have been set can be cleared together.

1 On the [SYSTEM] menu, select [AUTO SETUP], and display [AUTO SETUP]. Then select “ALL CLEAR”, and press the F2 dial to clear all the tables.

1 . AUTO SETUP
ALL CLEAR ↓

- The “Serial” settings are not cleared.

Selecting the remote cameras to be operated

Up to five remote cameras to be operated can be selected using the CAMERA STATUS/SELECTION buttons.

When one of the CAMERA STATUS/SELECTION buttons 1 to 5 is pressed, the indicator of the corresponding button lights.

The statuses of the remote cameras assigned to CAMERA STATUS/SELECTION buttons 1 to 5 can be identified by the lighting statuses of the indicators above the buttons.

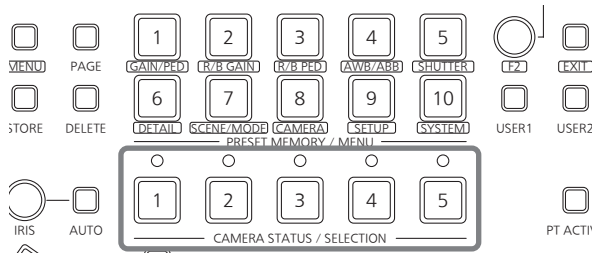

Indicator lighting statuses and remote camera statuses

Indicator lighting status	Remote camera status	The unit and remote camera connections
Off	<ul style="list-style-type: none"> No remote camera has been assigned to the corresponding button. ("NoAssign" is set for the remote camera connection.) The power of the remote camera has not been turned on. (*1, *2) 	IP connection/ Serial connection
Lights (*3) (orange)	The remote camera is in the standby status.	IP connection/ Serial connection
Blinking (orange)	It is not possible for the unit to be connected to the remote camera concerned because five other AW-RP50 remote camera controllers have already been connected.	IP connection
Lights (green)	The unit is now connected with the remote camera.	IP connection/ Serial connection
Blinking (green)	The remote camera concerned is connected to an AW-RP50 remote camera controller which is other than the unit.	IP connection
Lights (red)	The image of the remote camera concerned is now on the air. (The OA tally signal is received over the network or at the GPI input connector.)	IP connection/ Serial connection
Blinking (red)	The remote camera concerned is connected to another AW-RP50 remote camera controller, and the image of the its remote camera is now on the air.	IP connection

- *1:** Follow the steps set forth in the "How to turn the power of the remote cameras on and off" in the <Operations and Settings> Operating Instructions, and turn on the power of the remote camera.
- *2:** When the AW-PH400 is connected through the protocol converter (AW-IF400), the indicator also will go off when the LAN cable has been connected or disconnected.
Follow the steps set forth in the "How to turn the power of the remote cameras on and off" in the <Operations and Settings> Operating Instructions, and turn off the power of the remote camera and then turn it back on.
- *3:** This is "Off" when the AW-PH400 is connected through the protocol converter (AW-IF400).

Selecting the remote cameras to be operated

Up to 100 cameras can be divided into 1 to 20 groups by menu operations, and controlled by the unit. The selection procedure is described below.

1 Set the MENU button to ON.

Press the MENU button and light its indicator.

2 Set the PRESET MEMORY/MENU 8 button (CAMERA) to ON.

When the button is pressed and its indicator is lighted, the [CAMERA] menu is displayed on the LCD panel.

3 Press the F1 dial.

The GROUP SELECT item is displayed.

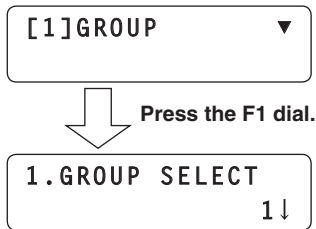

4 Turn the F2 dial, select the group, and then press the F2 dial.

The remote cameras assigned to the group selected here can be selected using the CAMERA STATUS/ SELECTION buttons.

Appearance

Unit: mm (inch)

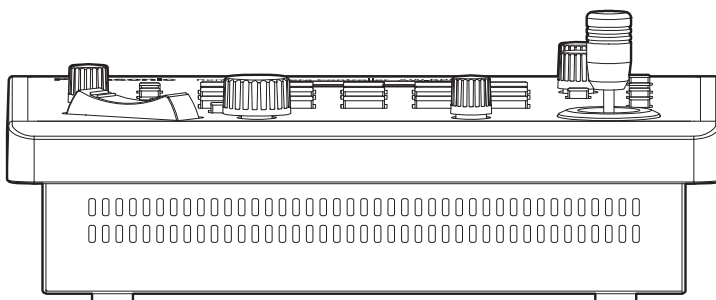
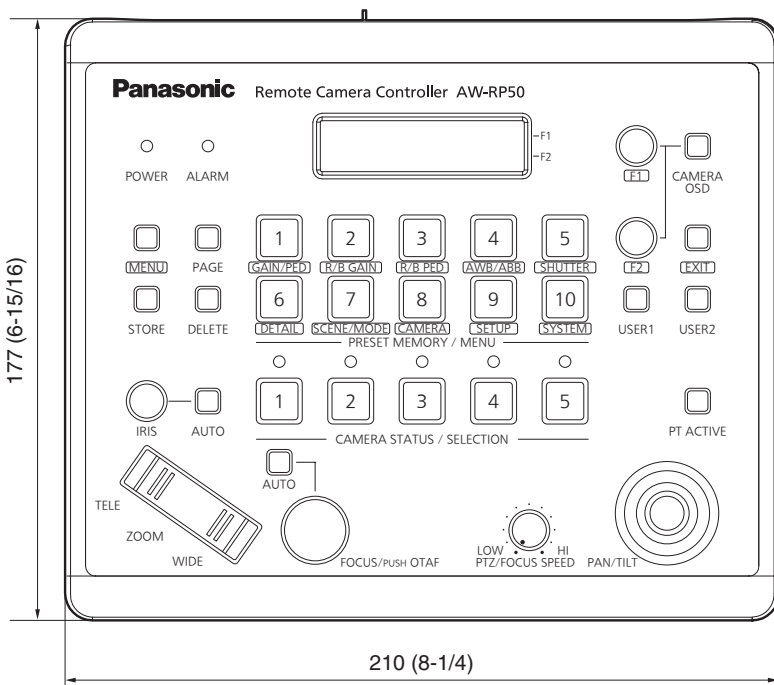
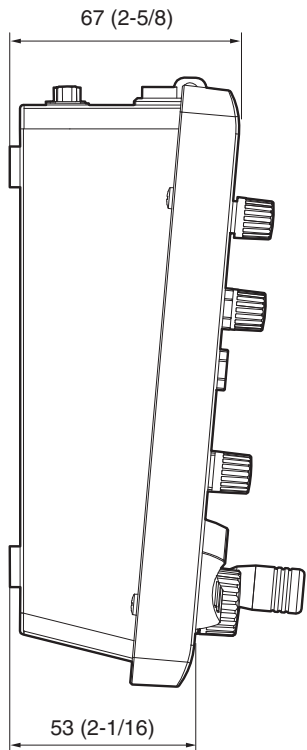
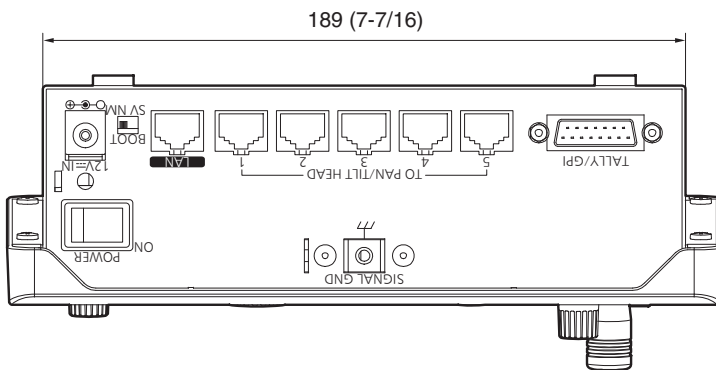

Specifications

Power requirements: DC 12 V \pm 10 %
(AC adapter provided)
Current consumption: 0.5 A (DC 12 V)

 indicates safety information.

■ GENERAL

Ambient operating temperature:
0 °C to +40 °C (32 °F to 104 °F)

Allowable humidity ranges:
10 % to 90 % (no condensation)

Mass:
Approx. 1.1 kg (2.43 lbs.)

Dimensions (W × H × D):
210 × 67 × 177 mm
(8-1/4" × 2-5/8" × 6-15/16")
[excluding protrusions]

■ Input/Output connector

LAN (RJ-45):
10BASE-T/100BASE-TX
Connecting cable: LAN cable, max. 100 meters
(328 ft.)

- When the unit is connected via a switching hub:
Straight cable (category 5 or above), STP
(Shielded Twisted Pair) cable recommended
- When the unit is connected directly:
Crossover cable (category 5 or above), STP
(Shielded Twisted Pair) cable recommended

TO PANTILT HEAD (RJ-45):
RS-422 (control signals for remote cameras)
Connecting cable:
Straight cable (category 5 or above)
max. 1000 meters (3280 ft.)

TALLY/GPI (D-sub 15-pin, female, inch thread):
TALLY IN:
5 inputs (for receiving photocoupler signals)
GPI IN:
4 inputs (for receiving photocoupler signals)
GPI OUT:
4 outputs (open collector outputs, negative logic)

■ AC adapter

Input:
AC 100 V to 240 V, 1.5 A, 50/60 Hz

Output:
DC 12 V, 2.5 A, 30 W

**The provided power cable is for 125 V AC or less.
Use it within AC 100 V to 120 V.**

Mass and dimensions shown are approximate.
Specifications are subject to change without notice.

Panasonic®

Panasonic Solutions Company

3 Panasonic Way, Secaucus, NJ 07094 Tel: 877-803-8492
www.panasonic.com/broadcast e-mail: MediaProServices.PSC@us.panasonic.com

Panasonic Canada Inc.

5770 Ambler Drive, Mississauga, Ontario L4W 2T3 Tel: 905-624-5010

Panasonic de Mexico S.A. de C.V.

Casa Matriz: Felix Cuevas No. 6 Pisos 2 y 3 Col. Tlacoquemecatl Del Valle Del.Benito Juárez México, D.F., C.P.03200
Tel: 55-5488-1000 Fax: 55-5575-6763

Panasonic Latin America, S.A.

Avenida Simon Bolivar, Edificio Panasonic P.O.Box 0816-03164 Panama, Republic of Panama
Tel: +507-229-2955 Fax: 507-229-5352

Panasonic do Brasil Ltda.

Rua Cubatão, 320 - 8 andar - Paraíso CEP: 04013-001 São Paulo - SP Tel: (11) 3889-4000 Fax: (11) 3889-4107

© Panasonic System Networks Co., Ltd. 2010

Printed in Japan
F0610Y1070 

Panasonic®

Operating Instructions <Operations and Settings>

Remote Camera Controller

Model No. **AW-RP50N**

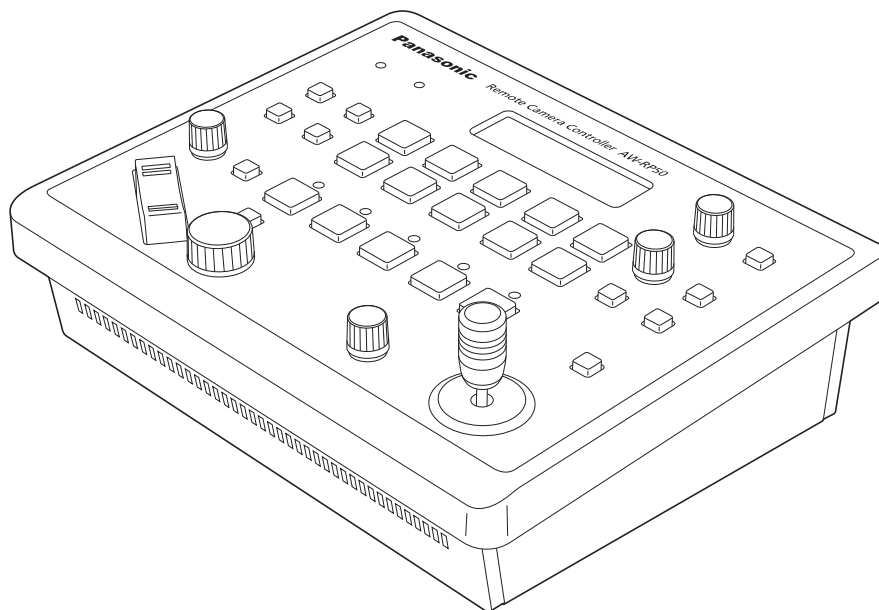

Contents

Before use	3	Setting the functions	18
Overview	3	Setting the remote camera operations	19
Trademarks and registered trademarks	3	Setting the speed at which to move to the position set by the preset memory.....	21
About copyright and licence.....	3	Setting the operations to be performed when a preset operation is executed.....	21
Concerning the ratings display.....	3	Returning the remote cameras to their home position	21
Disclaimer of warranty.....	3	Adjusting the panning, tilting, zooming and focusing speed.....	21
Network security.....	3	Setting the movement range of the remote camera (limiter function)	22
How to turn the power of the remote cameras on and off	4	Controlling the peripheral devices connected to the remote cameras.....	24
Setting and operating the preset memories	6	Adjusting the minimum lens zoom start speed.....	25
Registering data in the preset memories	6	Exercising external control over the preset memory data	25
Executing the preset data	7	Locking the button operations	26
Deleting the preset memory data.....	7	Adjusting the LCD panel backlight	26
Selecting the settings for a selected remote camera	8	Setting linkup with the switcher	27
Setting the gain	8	Switcher network settings	27
Setting the pedestal	8	Link setting.....	28
Setting the white balance.....	9	Setting the functions when the unit is linked with the switcher	29
Setting the black balance.....	12	Setting the image output and image input.....	29
Setting the shutter speed	13	Switcher settings	30
Setting the detail	13	Setting for the information to be displayed on the OSD	33
Setting the shooting mode	14	Checking the equipment alarm information	35
Specifying the color bars.....	14	Returning the unit to its factory status	36
Operating the menu items of the selected remote camera	15	Control interface for external devices	37
Setting the USER buttons	16	Setup Software	38
Tally settings	17	Installing the software	38
		IP settings	38
		Saving and loading data.....	41
		Referencing the network environment.....	42
		Table of menu items	43

How the model's Operating Instructions manuals are configured

- The manual of this Remote Camera Controller (hereafter, "the unit") is divided into two manuals: one is the <Operations and Settings> (this manual in the CD-ROM), and the other is the <Basics>. Before installing the unit, be sure to read the <Basics> to ensure that the unit is installed correctly.
- For the purposes of this manual, the model numbers of the units are given as listed in the table below.

Model number of unit	Model number given in manual	Model number of unit	Model number given in manual	Model number of unit	Model number given in manual
AW-HS50N	AW-HS50	AW-E650P	AW-E650	AW-PH650N	AW-PH650
AW-HE50HN	AW-HE50	AW-E750P	AW-E750	AW-IF400G	AW-IF400
AW-HE50SN	AW-HE50	AW-E860N	AW-E860	AK-HC1500G	AK-HC1500
AW-HE100N	AW-HE100	AW-PH360N	AW-PH360	AK-HC1800G	AK-HC1800
AW-HE870N	AW-HE870	AW-PH400P	AW-PH400		
AW-E350P	AW-E350	AW-PH405N	AW-PH405		

- In these instructions, the phrases "pan-tilt head and camera combination" and "camera integrated with a pan-tilt head" are both referred to collectively as "**remote camera**" except in places where specific equipment is mentioned.

Before use

■ Overview

This unit is a controller which is designed to control remote cameras (cameras integrated with pan-tilt heads) and pan-tilt head systems (which consist of pan-tilt heads and the cameras which are mounted on them).

By means of an IP connection, an operating environment where the unit is tied in with the AW-HE50 HD integrated camera and AW-HS50 compact live switcher is achieved.

When IP connections are used, the unit can be used to control up to 100 remote cameras.

When serial connections are used, up to five remote cameras and pan-tilt head systems can be controlled.

■ Trademarks and registered trademarks

- Microsoft, Windows, Windows Vista, Windows 7 and Internet Explorer are either registered trademarks or trademarks of Microsoft Corporation in the United States and other countries.
- Intel and Intel Core are trademarks or registered trademarks of Intel Corporation in the United States and other countries.
- Adobe and Reader are either registered trademarks or trademarks of Adobe Systems Incorporated in the United States and/or other countries.
- Other names of companies and products contained in these Operating Instructions may be trademarks or registered trademarks of their respective owners.

■ About copyright and licence

Distributing, copying, disassembling, reverse compiling, reverse engineering, and also exporting in violation of export laws of the software provided with this unit are expressly prohibited.

■ Concerning the ratings display

The unit's name, model number and electrical ratings are indicated on its bottom panel.

■ Disclaimer of warranty

IN NO EVENT SHALL Panasonic System Networks Co., Ltd. BE LIABLE TO ANY PARTY OR ANY PERSON, EXCEPT FOR REPLACEMENT OR REASONABLE MAINTENANCE OF THE PRODUCT, FOR THE CASES, INCLUDING BUT NOT LIMITED TO BELOW:

- ① ANY DAMAGE AND LOSS, INCLUDING WITHOUT LIMITATION, DIRECT OR INDIRECT, SPECIAL, CONSEQUENTIAL OR EXEMPLARY, ARISING OUT OF OR RELATING TO THE PRODUCT;
- ② PERSONAL INJURY OR ANY DAMAGE CAUSED BY INAPPROPRIATE USE OR NEGLIGENT OPERATION OF THE USER;
- ③ UNAUTHORIZED DISASSEMBLE, REPAIR OR MODIFICATION OF THE PRODUCT BY THE USER;
- ④ INCONVENIENCE OR ANY LOSS ARISING WHEN IMAGES ARE NOT DISPLAYED, DUE TO ANY REASON OR CAUSE INCLUDING ANY FAILURE OR PROBLEM OF THE PRODUCT;
- ⑤ ANY PROBLEM, CONSEQUENTIAL INCONVENIENCE, OR LOSS OR DAMAGE, ARISING OUT OF THE SYSTEM COMBINED BY THE DEVICES OF THIRD PARTY;
- ⑥ ANY INCONVENIENCE, DAMAGES OR LOSSES RESULTING FROM ACCIDENTS CAUSED BY AN INADEQUATE INSTALLATION METHOD OR ANY FACTORS OTHER THAN A DEFECT IN THE PRODUCT ITSELF;
- ⑦ LOSS OF REGISTERED DATA CAUSED BY ANY FAILURE;
- ⑧ ANY DAMAGES, CLAIMS, ETC. DUE TO LOSS OR LEAKAGE OF THE SETTING DATA SAVED ON THIS UNIT OR IN A PERSONAL COMPUTER.

■ Network security

As you will use this unit connected to a network, your attention is called to the following security risks.

- ① Leakage or theft of information through this unit
- ② Use of this unit for illegal operations by persons with malicious intent
- ③ Interference with or stoppage of this unit by persons with malicious intent

It is your responsibility to take precautions such as those described below to protect yourself against the above network security risks.

- Use this unit in a network secured by a firewall, etc.
- If this unit is connected to a network that includes PCs, make sure that the system is not infected by computer viruses or other malicious entities (using a regularly updated antivirus program, anti-spyware program, etc.).
- Refrain from connections that use public lines.

How to turn the power of the remote cameras on and off

How to turn the power of the remote cameras on

Follow one of the procedures below to turn on the power of the remote cameras.

- Turning on the power one camera at a time
- Turning on the power of a multiple number of cameras
 - Turning on the power of all the cameras
 - Turning on the power of the selected group of cameras

Each of these procedures is described in turn below.

Turning on the power one camera at a time

1 Select the remote camera.

When the corresponding CAMERA STATUS/ SELECTION button is held down, the name of the remote camera is displayed on the top line of the LCD panel and POWER OFF is displayed on the bottom line.

2 Turn the F2 dial to select "ON", and press the F2 dial.

The power of the selected remote camera is turned on.

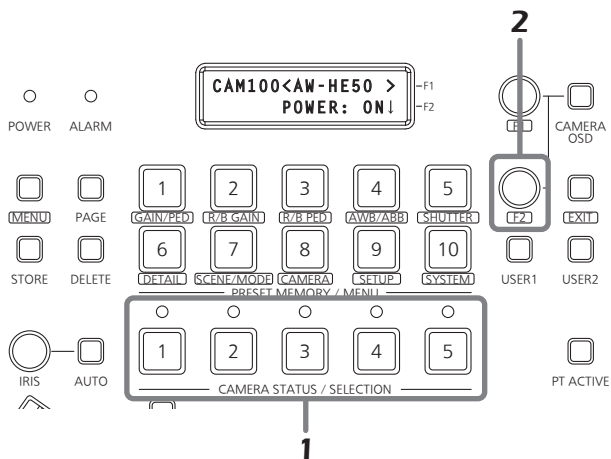

Turning on the power of a multiple number of cameras

1 Set the MENU button to ON.

Press the MENU button to light its indicator.

2 Set PRESET MEMORY/MENU 8 button (CAMERA) to ON.

When the button is pressed and its indicator is lighted, the [CAMERA] menu is displayed on the LCD panel.



3 Turn the F1 dial to display the [POWER] menu, and press the F1 dial.



Turning on the power of all the cameras

4 Turn the F2 dial to select "ALL ON", and press the F2 dial.



The power of all the remote cameras is now turned on.

Turning on the power of the selected group of cameras

4 Turn the F2 dial to select "GROUP ON", and press the F2 dial.



The power of the selected group of remote cameras is turned on.

How to turn the power of the remote cameras on and off

How to turn the power of the remote cameras off

Follow one of the procedures below to turn off the power of the remote cameras.

- Turning off the power one camera at a time
- Turning off the power of a multiple number of cameras
 - Turning off the power of all the cameras
 - Turning off the power of the selected group of cameras

Each of these procedures is described in turn below.

Turning off the power one camera at a time

1 Select the remote camera.

When the corresponding CAMERA STATUS/ SELECTION button is held down, the name of the remote camera is displayed on the top line of the LCD panel and POWER ON is displayed on the bottom line.

2 Turn the F2 dial to select "OFF", and press the F2 dial.

The power of the selected remote camera is turned off.

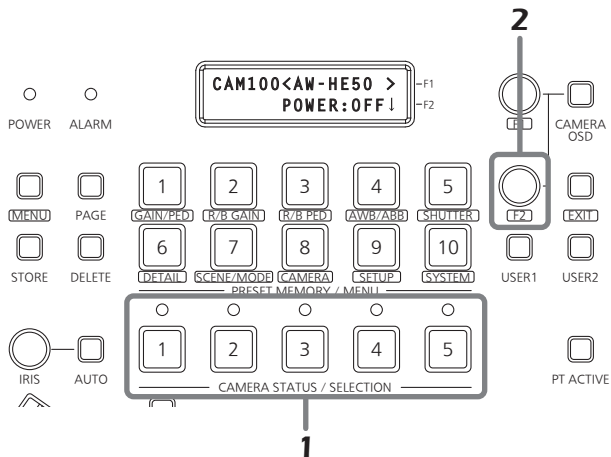

Turning off the power of a multiple number of cameras

1 Set the MENU button to ON.

Press the MENU button to light its indicator.

2 Set PRESET MEMORY/MENU 8 button (CAMERA) to ON.

When the button is pressed and its indicator is lighted, the [CAMERA] menu is displayed on the LCD panel.



3 Turn the F1 dial to display the [POWER] menu, and press the F1 dial.



Turning off the power of all the cameras

4 Turn the F2 dial to select "ALL OFF", and press the F2 dial.



The power of all the remote cameras is now turned off.

Turning off the power of the selected group of cameras

4 Turn the F2 dial to select "GROUP OFF", and press the F2 dial.



The power of the selected group of remote cameras is turned off.

Setting and operating the preset memories

This unit is provided with a function for registering the positions to be shot by the remote cameras and the settings of the remote cameras in the remote cameras themselves. Up to 100 sets of data (presets) can be registered in these memories.

The positions and settings listed below can be registered.

- Pan/tilt positions
- Zoom positions
- Focus positions
- Lens iris settings (manual iris only)
- White balance mode settings

Note

The number of position and setting data which can be registered as preset memory data differ from one remote camera to another. For further details, check the Operating Instructions of the model concerned.

■ Registering data in the preset memories

1 Press one of the **CAMERA STATUS/SELECTION** buttons 1 to 5 to select the remote camera to be operated.

2 Output the images to be shot by the camera to the monitor.

The camera angle to be registered is determined by operating the PAN/TILT lever and ZOOM button. If necessary, adjust the focus and iris as well.

3 Press the **STORE** button.

4 After pressing the **PAGE** button, press the **PRESET MEMORY/MENU** button to specify the “Page number” to be registered.

In this step, the “Page number” to be registered as the preset memory is specified.

- For details on the relationship between the “Preset number”, “Page number” and “Number on the page”, refer to the section entitled <Preset numbers and registered pages>.

5 Hold down the **PRESET MEMORY/MENU** button to specify the “Number on the page”.

The preset memory data is registered at the same time as the “Number on the page” is specified.

Note

When specifying the “Number on the page”, hold down the **PRESET MEMORY/MENU** button.

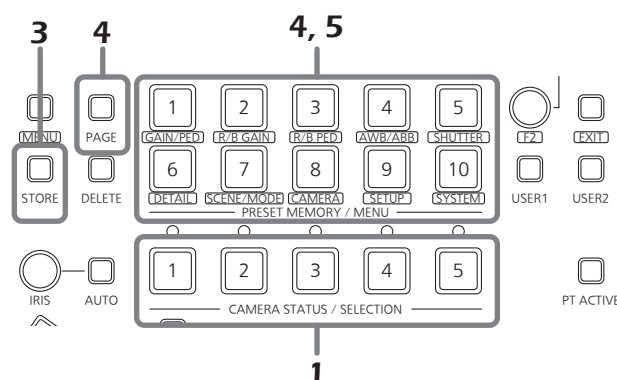

To register more data, repeat steps 2 to 5.

- When specifying a different “Number on the page” on the same “Page number”, it is registered by skipping step 4 and carrying out the operation in step 5 only.
- The PRESET MEMORY/MENU button corresponding to the preset number lights when preset memory data has been registered in the AW-HE50.

<Preset numbers and registered pages>

Preset number	Page number	Number on the page
1 to 10	1	1 to 10
11 to 20	2	1 to 10
21 to 30	3	1 to 10
31 to 40	4	1 to 10
41 to 50	5	1 to 10
51 to 60	6	1 to 10
61 to 70	7	1 to 10
71 to 80	8	1 to 10
81 to 90	9	1 to 10
91 to 100	10	1 to 10

Memo

Example: When specifying preset 21
 Press the following buttons in the order given:
 PAGE button → PRESET MEMORY/MENU 3 button →
 PRESET MEMORY/MENU button 1.

Setting and operating the preset memories

■ Executing the preset data

- 1 Press one of the CAMERA STATUS/SELECTION buttons 1 to 5 to select the remote camera to be operated.

Select the remote camera which is to be pointed at the camera angle registered in the preset memory.

- 2 After pressing the PAGE button, press the PRESET MEMORY/MENU button to specify the registered “Page number” of the preset memory.

In this step, specify the registered “Page number” of the preset memory.

- For details on the relationship between the “Preset number”, “Page number” and “Number on the page”, refer to the section entitled <Preset numbers and registered pages>.

- 3 Press the PRESET MEMORY/MENU button to specify the “Number on the page”.

The preset memory data is executed at the same time as the “Number on the page” are specified.

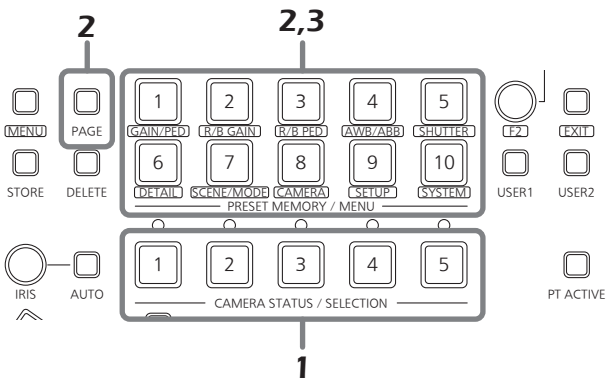

- When the preset memory data is executed, the preset number is displayed on the right side of the top level of the LCD panel.

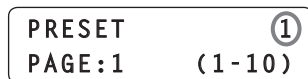

The preset number display is cleared when the power of the unit or remote camera has been turned off or when the camera group has been switched.

- In the case of the AW-HE50, the corresponding PRESET MEMORY/MENU button will go off, and then it will light again when preset memory data is executed. In the case of another remote camera connected serially, the corresponding PRESET MEMORY/MENU button will simply just light.

■ Deleting the preset memory data

Note

This function does not work with the AW-PH400.

- 1 Press one of the CAMERA STATUS/SELECTION buttons 1 to 5 to select the remote camera to be operated.

Select the remote camera whose preset memory data is to be deleted.

- 2 Press the DELETE button.

- 3 After pressing the PAGE button, press the PRESET MEMORY/MENU button to specify the “Page number” of the preset memory data to be deleted.

In this step, specify the “Page number” of the preset memory data to be deleted.

- For details on the relationship between the “Preset number”, “Page number” and “Number on the page”, refer to the section entitled <Preset numbers and registered pages>.

- 4 Hold down the PRESET MEMORY/MENU button to specify the “Number on the page”.

The preset memory data is deleted at the same time as the “Number on the page” is specified.

Note

When specifying the “Number on the page”, hold down the PRESET MEMORY/MENU button.

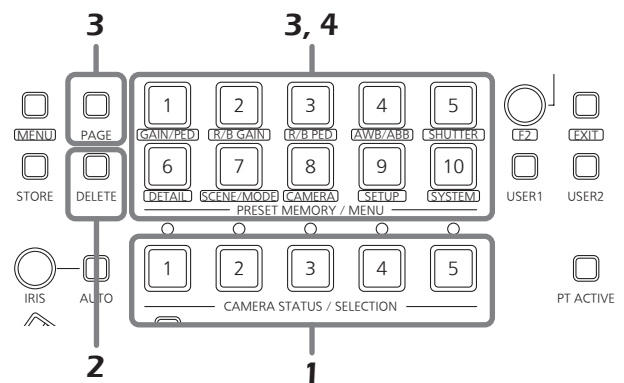

Selecting the settings for a selected remote camera

The following settings and adjustments can be performed for a selected remote camera directly from this unit.

- Gain
- Pedestal
- R and B gain values
- R and B pedestal values
- White balance
- Black balance
- Shutter speed
- Detail
- Shooting mode selection
- Color bar selection

Note

It is not possible to perform operations for those functions which are not supported by the model concerned.
For further details, refer to the "Table of menu items".

Setting the gain

In places which are too dark, increase the gain level; conversely, in places which are too light, reduce the gain level.

When "Auto" is selected, the light quantity is adjusted automatically.

When the gain is increased, the noise level also increases.

1 Set the MENU button to ON.

Press the MENU button to light its indicator.

2 Set the PRESET MEMORY/MENU 1 button (GAIN/PED) to ON.

When the button is pressed and its indicator lights, the [GAIN/PED] menu is displayed on the LCD panel.

3 Turn the F1 dial to select the setting.

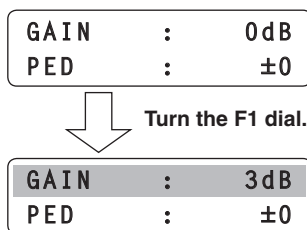

Note

The settings will differ depending on the remote camera connected.
For further details, check the Operating Instructions of the model concerned.

Setting the pedestal

Perform the black level (pedestal) adjustment in order to make it easier to see the very dark parts of the images. Adjustment in the "–" direction makes the parts closer to black; conversely, adjustment in the "+" direction makes the parts closer to white.

1 Set the MENU button to ON.

Press the MENU button to light its indicator.

2 Set the PRESET MEMORY/MENU 1 button (GAIN/PED) to ON.

When the button is pressed and its indicator lights, the [GAIN/PED] menu is displayed on the LCD panel.

3 Turn the F2 dial to select the setting.

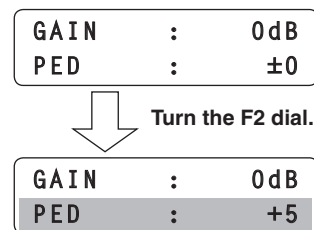

Note

The settings will differ depending on the remote camera connected.
For further details, check the Operating Instructions of the model concerned.

Selecting the settings for a selected remote camera

■ Setting the white balance

The ratio between RGB (three primary colors) is adjusted so that white will be reproduced accurately.

If the white balance is off, not only will white be reproduced poorly but the color tone of the entire picture will also deteriorate.

The white balance must be adjusted when using a remote camera for the first time or when the remote camera has not been used for a prolonged period of time. It must also be adjusted when changes have been made in the lighting conditions or brightness.

The white balance can be adjusted automatically or manually (fine adjustment after automatic adjustment).

In addition, preset values or the “auto tracking white adjustment (ATW)” which continues to adjust the white balance automatically all the time can be selected.

The results of white balance adjustments can be stored in memory A or memory B when “AWB A” or “AWB B” has been selected for the white balance.

■ Selecting the white balance mode

Follow the steps below to set the white balance mode.

1 Set the MENU button to ON.

Press the MENU button to light its indicator.

2 Set the PRESET MEMORY/MENU 4 button (AWB/ABB) to ON.

When the button is pressed and its indicator lights, the [AWB/ABB] menu is displayed on the LCD panel.

3 Turn the F1 dial to select the white balance mode.



The modes which can be selected differ depending on the remote camera connected.

Remote camera	Mode	Remote camera status
AW-HE50	AWB A	The status of the white balance registered in remote camera memory A is established.
	AWB B	The status of the white balance registered in remote camera memory B is established.
	ATW	In this mode, the white balance is automatically adjusted continuously all the time and automatically compensated even when the light source or color temperature has changed.
AW-HE100 AW-HE870 AW-E860 AW-E750 AW-E650 AW-E350	AWB A	The status of the white balance registered in remote camera memory A is established.
	AWB B	The status of the white balance registered in remote camera memory B is established.
	3200K	The status of the white balance which was adjusted at a brightness of 3200K is established.
	5600K	The status of the white balance which was adjusted at a brightness of 5600K is established.
	ATW	In this mode, the white balance is automatically adjusted continuously all the time and automatically compensated even when the light source or color temperature has changed.
AK-HC1500 AK-HC1800	—	—

Selecting the settings for a selected remote camera

Automatically adjusting the white balance

Set the automatic adjustment if the coloring appears unnatural under certain light sources or other conditions. If the white serving as the reference can be recognized, it is possible to shoot with natural coloring.

Memo

When the white balance is adjusted, the R and B GAIN values are set to "±0".

1 Set the MENU button to ON.

Press the MENU button to light its indicator.

2 Set the PRESET MEMORY/MENU 4 button (AWB/ABB) to ON.

When the button is pressed and its indicator lights, the [AWB/ABB] menu is displayed on the LCD panel.

3 Turn the F1 dial to select the place where the white balance is to be stored.

Select "AWB A" or "AWB B" to select the place where the white balance is stored.



- This step need not be taken when the AK-HC1500 or AK-HC1800 is used as the remote camera.

4 Turn the F2 dial to select AWB, and press the F2 dial.

The remote camera now automatically adjusts the white balance, and registers it at the place selected in step 3.

When automatic adjustment is performed, the following details are displayed on the LCD panel.

AWB ACTIVE:

This appears while AWB is being executed.

AWB OK:

This appears for 3 seconds after AWB is completed successfully.

AWB NG:

This appears for 3 seconds after AWB is completed unsuccessfully.

(AWB was executed while ATW, 3200K or 5600K was selected.)

- If it was not possible to adjust the white balance properly, change the brightness, iris, subject, light source or other aspect, and try adjusting it again.

Note

The settings will differ depending on the remote camera connected.

For further details, check the Operating Instructions of the model concerned.

Selecting the settings for a selected remote camera

Manually adjusting the white balance (Setting the R and B gain values)

- 1 As with the automatic adjustment, fill the screen with a white subject.**
- 2 Connect a waveform monitor or color monitor to the video output connector on the currently selected remote camera.**
- 3 Set the MENU button to ON.**
Press the MENU button to light its indicator.
- 4 Set the PRESET MEMORY/MENU 2 button (R/BGAIN) to ON.**
When the button is pressed and its indicator lights, the [R/BGAIN] menu is displayed on the LCD panel.
- 5 Turn the F1 dial to select the R gain setting; similarly, turn the F2 dial to select the B gain setting.**

RGAIN	:	±0	← F1 dial
BGAIN	:	±0	← F2 dial

Note

The settings will differ depending on the remote camera connected.
For further details, check the Operating Instructions of the model concerned.

Auto tracking white adjustment (ATW)

This function provides compensation automatically so that the white balance is adjusted even when the light source or color temperature changes during shooting, so that images that appear the least odd (that is, the most natural looking) are produced.

- 1 Set the MENU button to ON.**
Press the MENU button to light its indicator.
- 2 Set the PRESET MEMORY/MENU 4 button (AWB/ABB) to ON.**
When the button is pressed and its indicator lights, the [AWB/ABB] menu is displayed on the LCD panel.
- 3 Turn the F1 dial to select ATW.**

AWB MOD :	ATW↓
SET :	AWB↓

- If there is no white on the screen, it may not be possible to compensate the white balance properly. Similarly, under certain light source and color temperature conditions, it may not be possible to compensate the white balance properly.

Note

The settings will differ depending on the remote camera connected.
For further details, check the Operating Instructions of the model concerned.

Selecting the settings for a selected remote camera

■ Setting the black balance

The black balance must be adjusted when using a remote camera for the first time or when the remote camera has not been used for a prolonged period of time.

It must also be adjusted when significant changes have occurred in the ambient temperature or at the change of the seasons.

If the camera is used with the same settings and under the same conditions, the black balance need not be adjusted again.

When the black balance is adjusted again, the previous memory data will be erased and replaced with the new black balance settings.

When the black balance is set, the R and B pedestal adjustment settings are returned to ± 0 .

Automatically adjusting the black balance

1 Set the MENU button to ON.

Press the MENU button to light its indicator.

2 Set the PRESET MEMORY/MENU 4 button (AWB/ABB) to ON.

When the button is pressed and its indicator lights, the [AWB/ABB] menu is displayed on the LCD panel.

3 Turn the F2 dial to select ABB, and press the F2 dial.

AWB MOD:	AWB	B↓
SET	:	ABB↓

The remote camera now automatically adjusts the black balance.

When automatic adjustment is performed, the following details are displayed on the LCD panel.

ABB ACTIVE:

This appears while ABB is being executed.

ABB OK:

This appears for 3 seconds after ABB was completed successfully.

ABB NG:

This appears for 3 seconds after ABB was completed unsuccessfully.

Note

The settings will differ depending on the remote camera connected.

For further details, check the Operating Instructions of the model concerned.

Manually adjusting the black balance (Setting the R and B pedestal)

1 Connect a waveform monitor or color monitor to the video output connector on the currently selected remote camera.

2 Set the MENU button to ON.

Press the MENU button to light its indicator.

3 Set the PRESET MEMORY/MENU 3 button (R/BPED) to ON.

When the button is pressed and its indicator lights, the [R/BPED] menu is displayed on the LCD panel.

4 Turn the F1 dial to select the R pedestal setting; similarly, turn the F2 dial to select the B pedestal setting.

RPED	:	± 0	← F1 dial
BPED	:	± 0	← F2 dial

Note

The settings will differ depending on the remote camera connected.

For further details, check the Operating Instructions of the model concerned.

Selecting the settings for a selected remote camera

■ Setting the shutter speed

The shutter mode and shutter speed of the remote camera can be selected.

1 Set the MENU button to ON.

Press the MENU button to light its indicator.

2 Set the PRESET MEMORY/MENU 5 button (SHUTTER) to ON.

When the button is pressed and its indicator lights, the [SHUTTER] menu is displayed on the LCD panel.

3 Turn the F1 dial to select the shutter mode.

When "Step" has been selected as the shutter mode, the shutter speed can be selected by turning the F2 dial.

SHUTTER:	Step↓	← F1 dial
SPEED :	1/100	← F2 dial

Notes

- The settings will differ depending on the remote camera connected.
For further details, check the Operating Instructions of the model concerned.
- When a remote camera connected serially is selected and its shutter speed is set, and then a remote camera in another group is assigned to the CAMERA STATUS/SELECTION button, the shutter speed will be set to "1/100" when a menu operation is next performed.

■ Setting the detail

The image detail (image sharpness) can be adjusted.

1 Set the MENU button to ON.

Press the MENU button to light its indicator.

2 Set the PRESET MEMORY/MENU 6 button (DETAIL) to ON.

When the button is pressed and its indicator lights, the [DETAIL] menu is displayed on the LCD panel.

3 Turn the F1 dial to select On or Off.

4 Turn the F2 dial to select the detail level.

DETAIL :	On	← F1 dial
LEVEL :	LOW	← F2 dial

Note

The settings will differ depending on the remote camera connected.
For further details, check the Operating Instructions of the model concerned.

Selecting the settings for a selected remote camera

■ Setting the shooting mode

Select the shooting mode that matches the shooting conditions.

Select the mode according to the shooting conditions and your preferences.

1 Set the MENU button to ON.

Press the MENU button to light its indicator.

2 Set the PRESET MEMORY/MENU 7 button (SCENE/MODE) to ON.

When the button is pressed and its indicator lights, the [SCENE/MODE] menu is displayed on the LCD panel.

3 Turn the F1 dial to select the shooting mode.

SCENE	:	MANU1↓
MODE	:	CAM↓

Note

The settings will differ depending on the remote camera connected.
For further details, check the Operating Instructions of the model concerned.

■ Specifying the color bars

The images to be output from the remote camera can be switched between the “camera images” and “color bars”.

1 Set the MENU button to ON.

Press the MENU button to light its indicator.

2 Set the PRESET MEMORY/MENU 7 button (SCENE/MODE) to ON.

When the button is pressed and its indicator lights, the [SCENE/MODE] menu is displayed on the LCD panel.

3 Turn the F2 dial to select “CAM” (camera image) or “BAR” (color bars).

SCENE	:	MANU1↓
MODE	:	BAR↓

Operating the menu items of the selected remote camera

The menu operations of the remote cameras can be operated from the unit for the remote camera which is now selected. The CAMERA OSD button, F1 dial and F2 dial are used to perform the operations.

When the CAMERA OSD button is held down, its indicator lights, and the on-screen menu of the selected remote camera is displayed as the output image of the remote camera.

When the button is held down again while its indicator is lighted, the menu is cleared, and the indicator goes off.



Table of operations

Remote camera	Menu ON/OFF	Dial operation	Menu operation
AW-HE50	Hold down the CAMERA OSD button.	Turn the F1 dial. (Turn it clockwise.)	<ul style="list-style-type: none"> Moves (downward) to an item. Changes (increments) the setting.
		Turn the F1 dial. (Turn it counterclockwise.)	<ul style="list-style-type: none"> Moves (upward) to an item. Changes (decrements) the setting.
		Press the F1 dial.	Enters the setting.
AK-HC1500 AK-HC1800 AW-HE870	Hold down the CAMERA OSD button.	Turn the F1 dial. (Turn it clockwise.)	<ul style="list-style-type: none"> Moves (downward) to an item. Changes (decrements) the setting.
		Turn the F1 dial. (Turn it counterclockwise.)	<ul style="list-style-type: none"> Moves (upward) to an item. Changes (increments) the setting.
		Press the F1 dial.	Enters the setting.
AW-E350 AW-E650 AW-E750 AW-E860 AW-HE100	Hold down the CAMERA OSD button.	Turn the F1 dial. (Turn it clockwise.)	Moves (downward) to an item.
		Turn the F1 dial. (Turn it counterclockwise.)	Moves (upward) to an item.
		Press the F1 dial.	Enters the setting.
		Turn the F2 dial. (Turn it clockwise.)	<ul style="list-style-type: none"> Enters the setting. Changes (increments) the setting.
		Turn the F2 dial. (Turn it counterclockwise.)	Changes (decrements) the setting.

Notes

- The “on” and “off” of the indicator in the CAMERA OSD button may not correspond exactly to the menu display and menu non-display when another remote camera has been selected while remote camera menu operations are being performed from the unit or when the CAMERA OSD function is set to OFF by a remote camera. In addition, the menu operations may not be performed properly.
- The operations differ depending on the remote camera model. For details on the menu items which are displayed, check the Operating Instructions of the model concerned.

Setting the USER buttons

Menu items can be assigned to the two USER buttons (USER1, USER2).

The target function can be activated simply by pressing the USER button (USER1 or USER2).

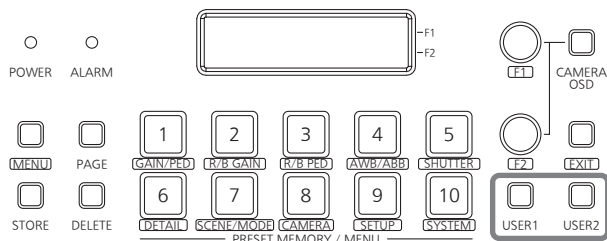

Menu item	Details of operation performed	
SWLINK	This sets the link control between the unit and switcher.	On: Enable Off: Disable
BUSCONT	This is the bus switching setting.	On: Enable Off: Disable
FASIST	This sets the focus assist function.	On: Enable Off: Disable
CAMSEL	This displays icons at the bottom left of the images from the remote camera selected by the unit on the multi view display of the switcher.	On: Display Off: Non-display
TALLY_IP	This sends the tally information sent periodically by UDP from the switcher to the remote camera.	On: Enable Off: Disable
CAMINF	This sends the camera information of the remote camera selected to the switcher.	On: Enable Off: Disable
AWB	AWB is executed when the USER button, in which AWB has been assigned, is pressed. When AWB is executed successfully, the indicator of the button goes off; conversely, when it is not executed successfully, it blinks.	
ABB	ABB is executed when the USER button, in which ABB has been assigned, is pressed. When ABB is executed successfully, the indicator of the button goes off; conversely, when it is not executed successfully, it blinks.	
POWER OFF	When the USER button in which POWER OFF has been assigned is held down, the indicator of the button lights for an instant, and power OFF is requested for all the remote cameras connected.	

■ Registering functions in the USER buttons

1 Set the MENU button to ON.

Press the MENU button to light its indicator.

2 Set the PRESET MEMORY/MENU 9 button (SETUP) to ON.

When the button is pressed and its indicator lights, the [SETUP] menu is displayed on the LCD panel.



3 Press the F1 dial.

4 Turn the F1 dial to display [USER1] or [USER2].

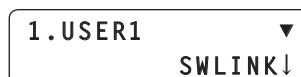

5 Turn the F2 dial to select the item to be assigned, and press the F2 dial.

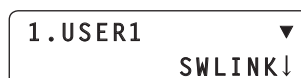

Turn the F2 dial, and then press it.



Tally settings

Set enable (On) or disable (Off) for tally ON which provides the tally instructions to the remote camera in response to tally requests received via the GPI and network.

1 Set the MENU button to ON.

Press the MENU button to light its indicator.

2 Set PRESET MEMORY/MENU 8 button (CAMERA) to ON.

When the button is pressed and its indicator is lighted, the [CAMERA] menu is displayed on the LCD panel.



3 Turn the F1 dial to display the [TALLY] menu, and press the F1 dial.

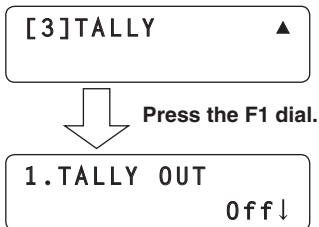

4 Turn the F2 dial to select On or Off, and then press the F2 dial to enter the selection.

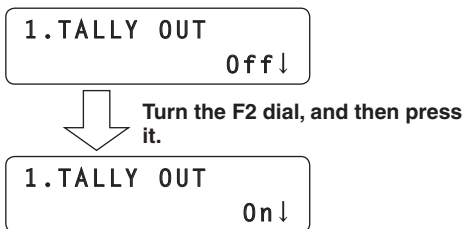

Setting the functions

This section describes how the unit's functions are set. The following functions can be set.

- Setting of the remote camera operations
- Registration of functions in the USER buttons
- Setting the speed at which to move to the preset memory setting position
- Setting the control items used when preset data is executed
- Controlling the peripheral devices connected to the remote cameras
 - ND filter
 - AC adapter (AW-PS300A)
 - Defroster
 - Wiper
 - Heater, fan
 - Halogen lamp
- Assignment of preset data when emergency interrupts occur
- Locking of button operations

The settings are established using the [SETUP] menu. First, the basic menu operations will be described.

1 Set the MENU button to ON.

Press the MENU button to light its indicator.

2 Set the PRESET MEMORY/MENU 9 button (SETUP) to ON.

When the button is pressed and its indicator lights, the [SETUP] menu is displayed on the LCD panel.



3 Turn the F1 dial to display the target menu item, and press the F1 dial.

For details on the [SETUP] menu items, refer to the "Table of menu items".

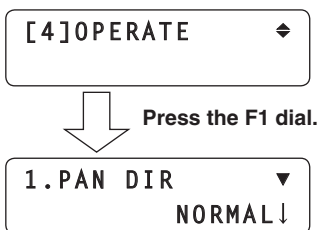

4 Turn the F1 dial to select the target menu item.

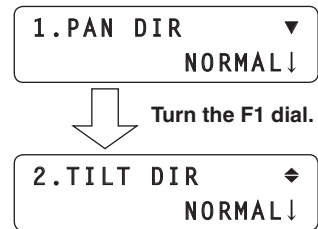

5 Turn the F2 dial to select the setting. Then press the F2 dial to change the setting.

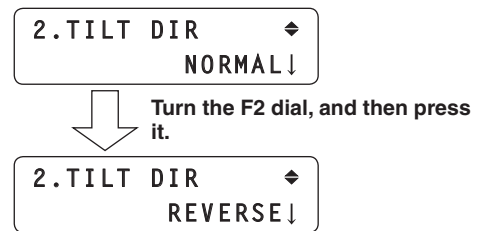

Setting the functions

■ Setting the remote camera operations

Set these operations by selecting the [SETUP] menu followed by the [OPERATE] menu.



● Setting the pan, tilt, zoom and focus operation directions

Set the directions in which the remote camera is to move when the panning, tilting, zooming or focusing operation has been initiated from the unit.

■ Setting the panning direction

From the [SETUP] menu, select [OPERATE] and display [PAN DIR]. Then select either "NORMAL" or "REVERSE".



This sets the operation of the remote camera in the horizontal direction in response to the horizontal manipulation of the PAN/TILT lever.

When "NORMAL" is selected as the setting, the remote camera will move to the left when the PAN/TILT lever is leaned toward the left and, conversely, it will move to the right when the lever is leaned toward the right.

When "REVERSE" is selected, the remote camera will move in the opposite directions.

■ Setting the tilting direction

From the [SETUP] menu, select [OPERATE] and display [TILT DIR]. Then select either "NORMAL" or "REVERSE".



This sets the operation of the remote camera in the vertical direction in response to the vertical manipulation of the PAN/TILT lever.

When "NORMAL" is selected as the setting, the remote camera will move upward when the PAN/TILT lever is leaned away from you and, conversely, it will move downward when the lever is leaned toward you.

When "REVERSE" is selected, the remote camera will move in the opposite directions.

■ Setting the zooming direction

From the [SETUP] menu, select [OPERATE] and display [ZOOM DIR]. Then select either "NORMAL" or "REVERSE".



This sets the zooming operation of the lens in response to the operation of the ZOOM button.

When "NORMAL" is selected as the setting, the lens zooms toward the tele end when the TELE side of the ZOOM button is pressed and, conversely, it will zoom toward the wide end when the WIDE side is pressed.

When "REVERSE" is selected, the lens will move in the opposite directions.

■ Setting the focusing direction

From the [SETUP] menu, select [OPERATE] and display [FOCUS DIR]. Then select either "NORMAL" or "REVERSE".



This sets the focusing operation of the lens in response to the operation of the FOCUS/PUSH OTAF dial.

When "NORMAL" is selected as the setting, the lens focus moves toward the far end when the dial is turned clockwise and, conversely, it will move toward the near end when the dial is turned counterclockwise.

When "REVERSE" is selected, the lens will move in the opposite directions.

Setting the functions

● Settings when the remote camera moves horizontally or vertically during tele shooting

During tele shooting, the remote camera's pan/tilt operation are slowed down to make positioning easier.

Note

This function takes effect when the unit is connected to the AW-HE50. It does not work with any other models.

From the [SETUP] menu, select [OPERATE] and display [SPEED WITH Z]. Then set the movement speed.

5. SPEED WITH Z ◆
Off ↓

On: The speed at which the remote camera moves is reduced.

Off: The remote camera moves at the normal speed.

● Selecting the control items (pan, tilt, zoom and focus)

Select the control items for the currently selected remote camera.

From the [SETUP] menu, select [OPERATE] and display [SPEED TARGET]. Then select the control item.

6. SPEED TARGET ◆
P/T/Z/F ↓

P/T/Z/F:

The operation speed setting takes effect for panning, tilting, zooming and focusing.

P/T:

The operation speed setting takes effect for panning and tilting.

● Switching from focus control to iris control or vice versa

It is possible to switch the control, which is implemented by dial and button operations, from focus control to iris control (or vice versa).

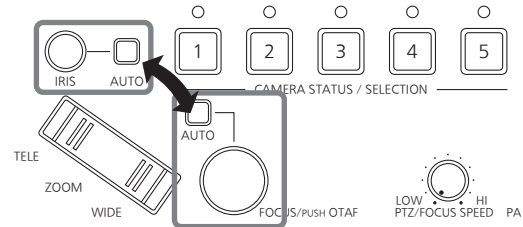

From the [SETUP] menu, select [OPERATE] and display [FOCUS/IRIS]. Then select either "STANDARD" or "EXCHANGE".

7. FOCUS/IRIS ◆
STANDARD ↓

When "EXCHANGE" is selected as the setting, focus control and iris control are switched.

When "STANDARD" is selected, the original control is restored.

● Setting the PAN/TILT lever inclination and speed

The correlation between angle and operating speed when the PAN/TILT lever is inclined can be adjusted.

From the [SETUP] menu, select [OPERATE] and display [P/T CURV]. Then set the correlation between the lever angle and its operating speed.

8. P/T CURV ▲
1 ↓

- The higher the value selected, the slower the operating speed.

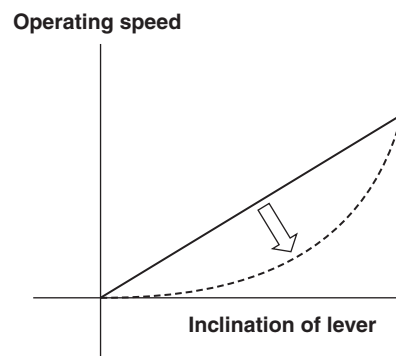

Setting the functions

■ Setting the speed at which to move to the position set by the preset memory

The speed at which to move to the position where the remote camera has been set to be in the preset memory when the preset operation is conducted can be set.

From the [SETUP] menu, select [PRESET] and display [DIAG SPEED]. Then set the speed.

The higher the setting, the faster the operating speed.



■ Setting the operations to be performed when a preset operation is executed

The operations which the remote camera is to be performed when the preset operation is conducted can be set.

From the [SETUP] menu, select [PRESET] and display [SCOPE]. Then set the operations to be performed.



The operations that the camera performs when a preset operation is executed differ depending on the mode selected.

Mode	Operations performed
MODE A	Pan, tilt, zoom, focus, iris, gain, white balance
MODE B	Pan, tilt, zoom, focus, iris
MODE C	Pan, tilt, zoom

Note

This function takes effect when the unit is connected to the AW-HE50. It does not work with any other models.

■ Returning the remote cameras to their home position

The remote cameras connected can be returned to their home position.

From the [SETUP] menu, select [PRESET] and display [HOME POSITION]. Then press the F2 dial.



■ Adjusting the panning, tilting, zooming and focusing speed

The speed is adjusted uniformly for the panning, tilting, zooming and focusing together.

When the PTZ/FOCUS SPEED dial is turned clockwise, the speed is increased; conversely, when it is turned counterclockwise, it is reduced.

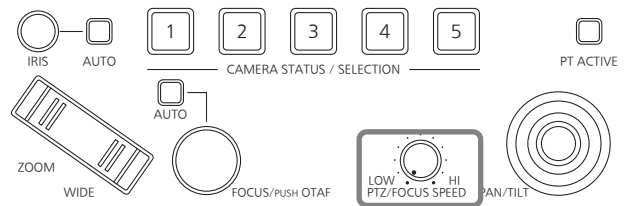

From the [SETUP] menu, select [OPERATE] and display [SPEED TARGET]. If P/T is selected, the speed adjustment is confined to panning and tilting only.

In this case, the zooming and focusing speed is fixed to the speed which was set immediately before P/T was selected.

Setting the functions

■ Setting the movement range of the remote camera (limiter function)

This unit has a limiter function which is a function that limits the movement range of the remote cameras.

There are four limiter positions: the upper, lower, left and right limits of the movement range.

When the AW-HE50 is used:

Depending on the nature of the AW-HE50's installation location, there may be some subjects inside its movement range which it is not desirable or necessary to shoot. In cases like this, the shooting range of the AW-HE50 can be limited by setting limiters in front of those subjects which are not to be shot.

When any other remote camera is used:

Depending on the installation position, there may be an obstruction in the movement range, and the remote cameras may come into contact with this obstruction.

If the remote cameras come into contact with an obstruction, trouble or accidents may result.

In cases like this, a limiter can be set in front of the obstruction to prevent contact.

● Setting the upper limit

From the [SETUP] menu, select [PTZ ADJ] and display [LIMIT UP]. Then set the upper limit.

The setting that is displayed differs between the AW-HE50 and other remote cameras.

Display that appears with the AW-HE50

The current setting status is displayed in the LIMIT UP item.

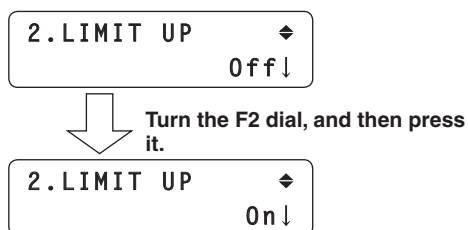

Display that appears with other remote cameras

The setting status is displayed after the completion of the setting in the LIMIT UP item.

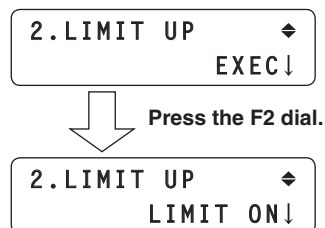

● Setting the lower limit

From the [SETUP] menu, select [PTZ ADJ] and display [LIMIT DOWN]. Then set the lower limit.

The setting that is displayed differs between the AW-HE50 and other remote cameras.

Display that appears with the AW-HE50

The current setting status is displayed in the LIMIT DOWN item.

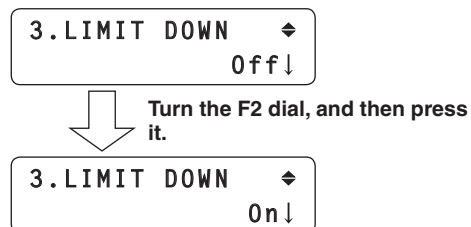

Display that appears with other remote cameras

The setting status is displayed after the completion of the setting in the LIMIT DOWN item.

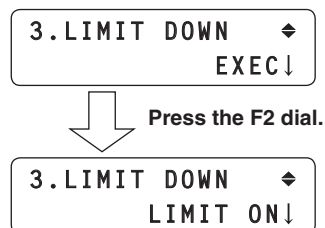

Setting the functions

● Setting the left limit

From the [SETUP] menu, select [PTZ ADJ] and display [LIMIT LEFT]. Then set the left limit.

The setting that is displayed differs between the AW-HE50 and other remote cameras.

Display that appears with the AW-HE50

The current setting status is displayed in the LIMIT LEFT item.

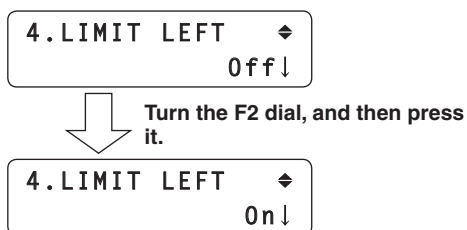

Display that appears with other remote cameras

The setting status is displayed after the completion of the setting in the LIMIT LEFT item.

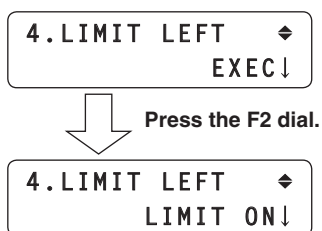

● Setting the right limit

From the [SETUP] menu, select [PTZ ADJ] and display [LIMIT RIGHT]. Then set the right limit.

The setting that is displayed differs between the AW-HE50 and other remote cameras.

Display that appears with the AW-HE50

The current setting status is displayed in the LIMIT RIGHT item.

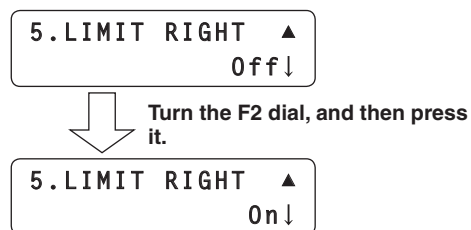

Display that appears with other remote cameras

The setting status is displayed after the completion of the setting in the LIMIT RIGHT item.

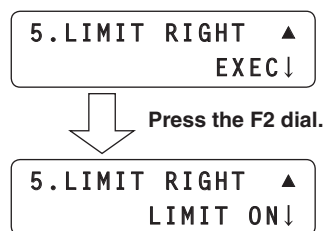

Setting the functions

■ Controlling the peripheral devices connected to the remote cameras

When any of the peripheral devices listed below are connected to the remote cameras, they can be controlled.

- ND filter
- AC adapter (AW-PS300A)
- Defroster
- Wiper
- Heater, fan
- Halogen lamp

Control is exercised using the FUNCTION item of the [SETUP] menu.

[6] FUNCTION ◆

■ Controlling an ND filter

This item is used to control the ND filter when using a lens with an ND filter function on the currently selected remote camera.

From the [SETUP] menu, select [FUNCTION] and display [ND FILTER]. Then select ND filter control.

1. ND FILTER ◆
Off↓

■ Controlling an AC adapter (AW-PS300A)

This item is used to control shorting and releasing of the OPTION SW CONTROL OUT connector when using an AC adapter (AW-PS300A) for the currently selected remote camera.

From the [SETUP] menu, select [FUNCTION] and display [OPTION]. Then select shorting or releasing.

2. OPTION ◆
Off↓

■ Controlling a defroster

This item is used to control a defroster when using a remote camera (AW-PH650 + camera) equipped with a defroster function as the currently selected remote camera.

From the [SETUP] menu, select [FUNCTION] and display [DEFROSTER]. Then select defroster On or Off.

3. DEFROSTER ◆
Off↓

■ Controlling a wiper

This item is used to control a wiper when using a remote camera (AW-PH650 + camera) equipped with a wiper function as the currently selected remote camera.

From the [SETUP] menu, select [FUNCTION] and display [WIPER]. Then select wiper On or Off.

4. WIPER ◆
Off↓

■ Controlling a heater/fan

This item is used to control a heater/fan when using a remote camera (AW-PH650 + camera) equipped with a heater or fan function as the currently selected remote camera.

From the [SETUP] menu, select [FUNCTION] and display [HEATER/FAN]. Then select heater/fan On or Off.

5. HEATER/FAN ◆
Off↓

■ Controlling a halogen lamp

This item is used to control the lighting (On) and extinguishing (Off) of the halogen lamp when a halogen lamp has been connected to the currently selected remote camera.

From the [SETUP] menu, select [FUNCTION] and display [LAMP]. Then select halogen lamp lighting (On) and extinguishing (Off).

6. LAMP ▲
Off↓

Setting the functions

■ Adjusting the minimum lens zoom start speed

This adjustment ensures that the lens zoom will start moving smoothly in line with the inclination of the ZOOM button when operating the lens zoom using the ZOOM button.

From the [SETUP] menu, select [PTZ ADJ] and display [Z MIN SPEED]. Then turn the F2 dial to set the compensation amount.



The lowest compensation amount is “1”, and the highest is “8”.

No compensation is provided at the “Off” setting. While observing the images on a monitor, hold down the ZOOM button slowly, and check whether the lens zoom starts moving smoothly.

■ Exercising external control over the preset memory data

Preset numbers can be assigned to execute presets for the selected remote cameras when signals have been input to the TALLY/GPI input/output connector.

The presets are assigned using the GPI item on the [SETUP] menu.



■ Setting the preset numbers

From the [SETUP] menu, select [GPI], and display [PRESET CTL1], [PRESET CTL2] or [PRESET CTL3]. Then set the camera number and preset number.



Any camera number from “CAM1” to “CAM100” or “ALL” can be selected.

- If “ALL” has been selected, it will not be possible to execute the preset operations for any remote cameras which have been set to “NoAssign” as the connection setting.
 - ☞ Refer to “Settings for connection with the remote cameras” (<Basics> Operating Instructions).

The preset number setting can be established for each GPI input.

- Input1: PRESET CTL1
- Input2: PRESET CTL2
- Input3: PRESET CTL3

Setting the functions

■ Locking the button operations

This disables the operation of the CAMERA OSD button and PRESET MEMORY/MENU buttons (1 to 7).

The button operations are locked using the MENU CTL item of the [SETUP] menu.



■ Setting button operation enable or disable

From the [SETUP] menu, select [MENU CTL] and display [MENU CONTROL]. Then set button operation enable or disable.



When "DISABLE" is selected, the following button operations are disabled:

- CAMERA OSD button
- PRESET MEMORY/MENU 1 to 7 buttons
(However, these buttons can still be used to execute preset settings.)

■ Adjusting the LCD panel backlight

The backlight of the LCD panel can be adjusted.

Make this adjustment using the LCD BL item on the [SETUP] menu.



■ Adjusting the backlight

From the [SETUP] menu, select [LCD BL] and display [BACKLIGHT]. Then set whether the backlight is to be turned on or off.



Setting linkup with the switcher

This setting is used to link the unit with an optional switcher (AW-HS50).

To link the unit with the switcher, the following settings must be established in the unit.

IP address (switcher) setting

[SYSTEM] menu → [SW IP ADR]

Assign information setting

[SYSTEM] menu → [SW CTL]

Link connection setting

[SETUP] menu → [SW LINK] → [SWLINK]

Settings at the switcher

For details on the settings selected at the switcher, refer to the Operating Instructions of the switcher.

Switcher network settings

1 Set the MENU button to ON.

Press the MENU button to light its indicator.

2 Set PRESET MEMORY/MENU 10 button (SYSTEM) to ON.

When the button is pressed and its indicator is lighted, the [SYSTEM] menu is displayed on the LCD panel.



3 Turn the F1 dial, display the SW IP ADR menu, and press the F1 dial.

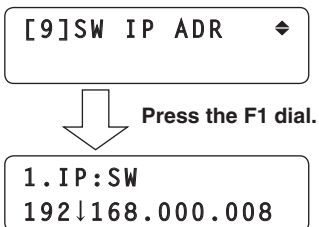

4 Turn the F2 dial, select the IP address, and then press the F2 dial to enter the selection.

Set the IP address which has been set in the switcher.

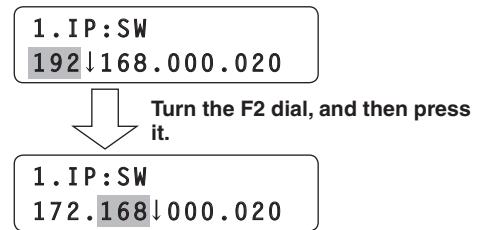

Input the IP address in four blocks of numerals. When input advances to the last block and the F2 dial is pressed, the IP address is entered.

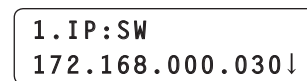

5 Press the EXIT button.

Operation now returns to the SW IP ADR menu.



6 Turn the F1 dial to display the SW CTL menu, and press the F1 dial.

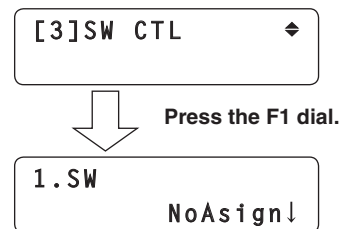

7 Turn the F2 dial to select "Network", and then press the F2 dial to enter the selection.

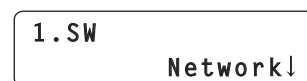

Setting linkup with the switcher

■ Link setting

1 Set the MENU button to ON.

Press the MENU button to light its indicator.

2 Set PRESET MEMORY/MENU 9 button (SETUP) to ON.

When the button is pressed and its indicator is lighted, the [SETUP] menu is displayed on the LCD panel.



3 Turn the F1 dial, display the SW LINK menu, and press the F1 dial.



Press the F1 dial.



4 Turn the F2 dial to select On, and then press the F2 dial to change the setting.



When "On" is selected as the item setting, the settings mentioned below take effect, and the link with the switcher is established.

Control can also be exercised by assigning this setting to a USER button.

Setting the functions when the unit is linked with the switcher

Set the various functions to be used when the unit is linked with the switcher.

■ Setting the image output and image input

This setting establishes the correlation between the image output (remote camera) and image input (switcher). By establishing the setting, the switcher is notified if a remote camera which has been set is selected when the remote cameras have been selected by the unit.

1 Set the MENU button to ON.

Press the MENU button to light its indicator.

2 Set PRESET MEMORY/MENU 10 button (SYSTEM) to ON.

When the button is pressed and its indicator is lighted, the [SYSTEM] menu is displayed on the LCD panel.



3 Turn the F1 dial, display the SW ASSIGN menu, and press the F1 dial.

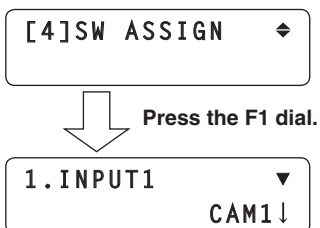

4 Turn the F1 dial to select the input line of the switcher.

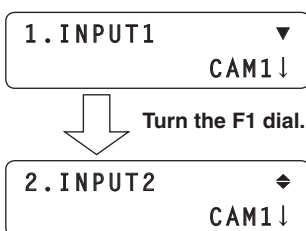

5 Turn the F2 dial, select the remote camera, and then press the F2 dial to enter the selection.

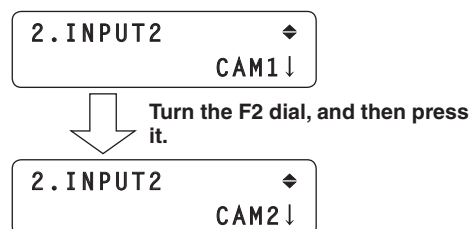

The switcher has five input lines: INPUT1 to INPUT5. Take the above steps to set the remote cameras for the input lines, and then operate the remote cameras.

- Select "NoAssign" if the switcher is not to be notified of the correlation setting when the remote cameras have been selected.

Setting the functions when the unit is linked with the switcher

Switcher settings

A setting for controlling the switcher linked with the unit is available.

It is established using the [SETUP] menu.

Before taking the steps described here, the steps for “Switcher network settings” and “Setting the image output and image input” must be taken.

First, the basic menu operations will be described.

1 Set the MENU button to ON.

Press the MENU button to light its indicator.

2 Set PRESET MEMORY/MENU 9 button (SETUP) to ON.

When the button is pressed and its indicator is lighted, the [SETUP] menu is displayed on the LCD panel.



3 Turn the F1 dial, display the SW LINK menu, and press the F1 dial.



4 Turn the F1 dial to select the menu item to be set.



5 Turn the F2 dial, select the settings, and then press the F2 dial to change the setting.



Bus switching

From the [SETUP] menu, select [SW LINK] and display [BUSCONT]. Then select On or Off.



When “On” is selected as the item setting, the materials set using the BUS item (described later) are sent from the remote camera to the switcher when the remote cameras has been selected using one of the unit’s CAMERA STATUS/SELECTION buttons.

Control can also be exercised by assigning this setting to a USER button.

Setting the functions when the unit is linked with the switcher

Bus setting

From the [SETUP] menu, select [SW LINK] and display [BUS]. Then set the material (AUX, PVW, PinP or KEY) to be sent to the switcher.



The materials set using this item are sent from the remote camera to the switcher when the remote camera has been selected using one of the unit's CAMERA STATUS/ SELECTION buttons.

Control can also be exercised by assigning this setting to a USER button (BUSCONT).

Focus assist setting

From the [SETUP] menu, select [SW LINK] and display [FASIST]. Then set On or Off.



When "On" is selected as this item's setting, the images of the AUX bus output from the switcher will be switched to the images of the remote camera selected by the unit. Conversely, when "Off" is selected, the switcher will switch the images of the AUX bus output from the switcher to the images of its multi view display.

Camera information setting

From the [SETUP] menu, select [SW LINK] and display [CAMSEL]. Then set On or Off.



When "On" is selected as the item setting, an icon appears at the bottom left of the image of the remote camera selected by the unit on the switcher's multi view display. When a remote camera has been selected, its information is sent from the unit to the switcher.

Setting the functions when the unit is linked with the switcher

OA tally setting

From the [SETUP] menu, select [SW LINK] and display [TALLY_IP]. Then set On or Off.



When “On” is selected as the item setting, the unit receives the tally information (tally ON/OFF) sent periodically from the switcher through the network, and it sends the ON or OFF instruction to the remote cameras in which changes have occurred.

[Concerning the tally information transferred through the network]

After receiving the tally information (Input1 to Input5) from the switcher through the network, the unit sends the ON or OFF instruction to the remote cameras.

Based on the relationship between the image output (remote camera) and image input (switcher) which have been set using the unit’s menu, the remote camera to which the tally instruction is sent in response to the tally information received from the switcher is identified, the tally indicator of that remote camera is lighted in red, and the tally ON instruction is sent to the remote camera.

The Tally ON instruction is also sent to the remote cameras which are not in the selected camera group.

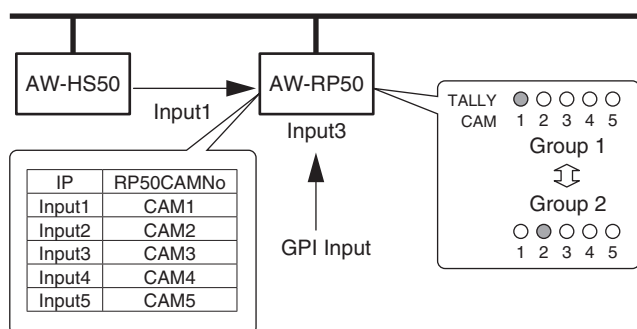

In response to inputs 1 to 5 from GPI Input, tally indicators CAM1 to CAM5 are lighted in red, and the tally ON instruction is sent to the remote cameras concerned. Only CAM1 to CAM5 serve as the GPI Input tally. This means that when a camera group other than No.1 is selected, the tally indicators will go off.

The following tally-related settings can be established using the menu.

- **Enabling/disabling the tally information instructions sent over the network**

If only the tally information from GPI is to be enabled, from the [SETUP] menu select [SW LINK], set [TALLY_IP] to Off, and disable the tally information instructions sent over the network.

- **Enabling/disabling the tally ON instructions sent to the remote cameras**

From the [CAMERA] menu, select [TALLY] and display [TALLY OUT]. Then set enable or disable for the tally ON instructions to be sent to the remote cameras in response to the tally requests from the GPI and over the network.

PAN/TILT lever control setting

This setting makes it possible to use the unit’s PAN/TILT lever as the switcher’s control lever.

From the [SETUP] menu, select [SW LINK] and display [P/T LEVER]. Then set Self or SW.



When “Self” has been selected as the setting, the unit’s PAN/TILT lever is used as the lever for operating the pan and tilt functions of the remote cameras.

When “SW” has been selected, the following information is sent to the switcher.

PAN/TILT lever: X, Y
ZOOM button: Size

Setting the functions when the unit is linked with the switcher

■ Setting for the information to be displayed on the OSD

This setting displays the remote camera information on the OSD of the monitor which is connected to the switcher to be linked to the unit.

The setting is established using the [SETUP] menu. Before taking the steps here, the steps for “Switcher network settings” and “Setting the image output and image input” described earlier must be taken.

First, the basic menu operations will be described.

1 Set the MENU button to ON.

Press the MENU button to light its indicator.

2 Set PRESET MEMORY/MENU 9 button (SETUP) to ON.

When the button is pressed and its indicator is lighted, the [SETUP] menu is displayed on the LCD panel.



3 Turn the F1 dial to display the SW DISP menu, and press the F1 dial.

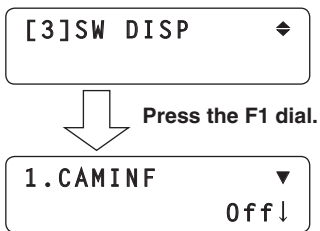

4 Turn the F1 dial to and select the menu item to be set.

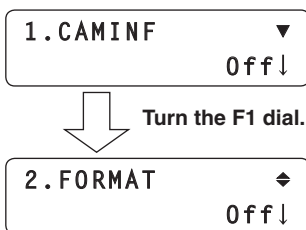

5 Turn the F2 dial to select On or Off, and then press the F2 dial to enter the selection.

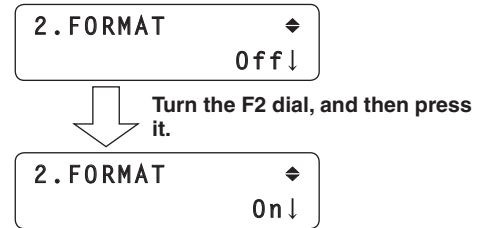

● Setting all the information displays together

From the [SETUP] menu, select [SW DISP] and display [CAMINF]. Then set On or Off.



When “On” is selected as the item setting, the information of the remote cameras set in “Setting the image output and image input” is sent to the switcher.

Control can also be exercised by assigning this setting to a USER button.

- ① Video format
(This is left blank when the video format of the remote camera cannot be recognized.)
- ② Scene file name (shooting mode)
- ③ Filter information
- ④ Remote camera alarm information
- ⑤ Shutter information (ON/OFF, shutter value)
- ⑥ Gain value
- ⑦ Iris value
- ⑧ Remote camera name
(displayed with up to 10 characters)

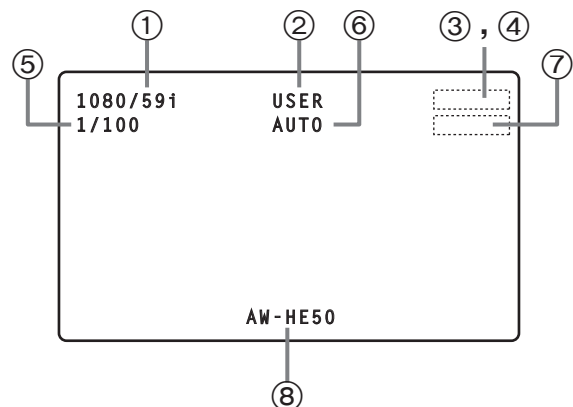

Setting the functions when the unit is linked with the switcher

● Setting each information item to be displayed

■ Video format

From the [SETUP] menu, select [SW DISP] and display [FORMAT]. Then set On or Off.

2. FORMAT ◆
Off↓

■ Remote camera name

From the [SETUP] menu, select [SW DISP] and display [CAMNAME]. Then set On or Off.

3. CAMNAME ◆
Off↓

■ Scene file name

From the [SETUP] menu, select [SW DISP] and display [SCENE]. Then set On or Off.

4. SCENE ◆
Off↓

■ Gain value

From the [SETUP] menu, select [SW DISP] and display [GAIN]. Then set On or Off.

5. GAIN ◆
Off↓

■ Shutter information

From the [SETUP] menu, select [SW DISP] and display [SHUTTER]. Then set On or Off.

6. SHUTTER ◆
Off↓

■ Iris value

From the [SETUP] menu, select [SW DISP] and display [IRIS]. Then set On or Off.

7. IRIS ◆
Off↓

■ Filter information

From the [SETUP] menu, select [SW DISP] and display [FILTER]. Then set On or Off.

8. FILTER ◆
Off↓

■ Remote camera alarm information

From the [SETUP] menu, select [SW DISP] and display [ALARM]. Then set On or Off.

9. ALARM ▲
Off↓

Checking the equipment alarm information

It is possible to check the alarm statuses of the unit and the remote cameras assigned to the CAMERA STATUS/SELECTION buttons.

1 Set the MENU button to ON.

Press the MENU button to light its indicator.

2 Set PRESET MEMORY/MENU 10 button (SYSTEM) to ON.

When the button is pressed and its indicator is lighted, the [SYSTEM] menu is displayed on the LCD panel.



3 Turn the F1 dial to display the ALARM menu, and press the F1 dial.



Press the F1 dial.



4 Turn the F1 dial to select the unit (POWER) or remote camera item (CAM1 to CAM100).

The alarm status is displayed underneath.



Turn the F2 dial.



[Select POWER]

The unit's power supply alarm can be checked.

No ALARM:

When the power supply is trouble-free.

ALARM:

When trouble has occurred in the power supply.

[Select CAM1 to CAM100]

The alarm statuses of the remote cameras currently assigned to the CAMERA STATUS/SELECTION buttons are displayed.

No ALARM:

Trouble-free.

FAN ALM:

Trouble has occurred in the cooling fan.

P/T ALM:

Trouble has occurred in the pan/tilt operation.

FAN ALM+P/T ALM:

Trouble has occurred in the cooling fan and pan/tilt operation.

Note

When an alarm has occurred, stop operation immediately, and be absolutely sure to contact your dealer.

Continued use may cause the unit to malfunction.

Returning the unit to its factory status

The unit's settings can be returned to the factory statuses. Two methods can be used: One method returns all the settings to the factory statuses, and the other returns only the [SETUP] menu settings to the factory statuses.

1 Set the MENU button to ON.

Press the MENU button to light its indicator.

2 Set PRESET MEMORY/MENU 10 button (SYSTEM) to ON.

When the button is pressed and its indicator is lighted, the [SYSTEM] menu is displayed on the LCD panel.



3 Turn the F1 dial to display the INITIALIZE menu, and press the F1 dial.

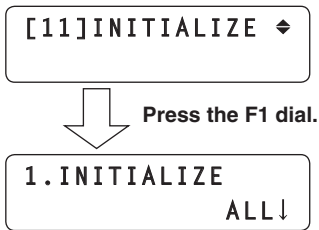

4 Turn the F2 dial to select the initializing mode.

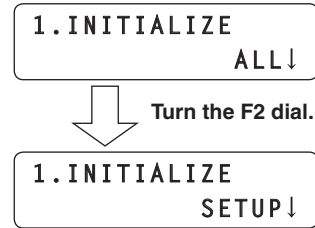

ALL:

The settings controlled by the unit are returned to the factory statuses.

SETUP:

Only the settings on the menus below are returned to the factory statuses.

[CAMERA] menu	
[2]	POWER
[3]	TALLY
[SETUP] menu	
[1]	USER
[2]	SW LINK
[3]	SW DISP
[4]	OPERATE
[5]	PRESET
[8]	GPI
[9]	LCD BL
[10]	MENU CTL

5 Press the F2 dial to initialize the settings.

Control interface for external devices

■ TALLY/GPI

TALLY IN 1 to TALLY IN 5 are contact input ports which are used to light the unit's tally indicators (above the CAMERA STATUS/SELECTION buttons).

The tally lamps light with contact input.

GPI IN 1 to GPI IN 4 are contact input ports which are used to control the unit from an external source.

GPI OUT 1 to GPI OUT 4 are open output ports which are used to output the statuses to an external source.

(D-sub 15-pin, female, inch thread)

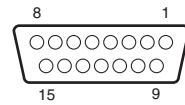

Pin No.	Signal	Description of signal	Operation
1	TALLY IN 1	CAM1 tally input	Contact input
9	TALLY IN 2	CAM2 tally input	
2	TALLY IN 3	CAM3 tally input	
10	TALLY IN 4	CAM4 tally input	
3	TALLY IN 5	CAM5 tally input	
11	GND	Ground	
4	GPI IN 1	Preset input 1	Contact input
12	GPI IN 2	Preset input 2	
5	GPI IN 3	Preset input 3	
13	GPI IN 4	Panel lock	
6	GPI OUT 1	Remote camera selection 0 *	Open collector output
14	GPI OUT 2	Remote camera selection 1 *	
7	GPI OUT 3	Remote camera selection 2 *	
15	GPI OUT 4	Alarm	
8	NC	Not used	

Example of GPI OUT connections

Ensure that the conditions given below are satisfied.

Dielectric strength: Max. DC 24 V

Current: Max. 50 mA

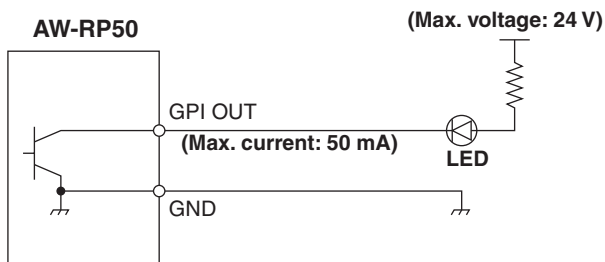

Example of TALLY IN and GPI IN connections

Provide contact inputs.

AW-RP50

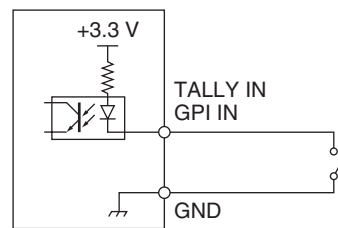

*: The selection statuses (CAMERA STATUS/SELECTION buttons 1 to 5) of the remote cameras can be monitored at GPI OUT 1 to GPI OUT 3.

CAMERA STATUS/SELECTION button	Remote camera selection 0 (GPI OUT 1)	Remote camera selection 1 (GPI OUT 2)	Remote camera selection 2 (GPI OUT 3)
1	On	Off	Off
2	Off	On	Off
3	On	On	Off
4	Off	Off	On
5	On	Off	On

Setup Software

The “Setup Software” is an application which enables the same functions as the unit’s automatic IP settings to be executed from the host computer.

This is used to set the network environment for operating the remote camera using the host computer.

It can save the setting data files in the host computer, and it can load the saved files and reflect them in the network environment.

For details, refer to the sections that follow.

Notes

When the settings are to be selected at the host computer using the “Setup Software”:

- Do not perform the operation at the unit.
- Do not start up the “Setup Software” in any other computer in the same network.
- Do not use the “Easy IP Setup Software” which is provided with the AW-HE50.

■ Installing the software

This section describes how to install the Setup Software.

1. Insert the CD-ROM provided with the unit into the CD-ROM drive of the host computer in which the software application is going to be installed.
2. Copy the entire folder containing “Setup Software” on the CD-ROM onto the hard disk drive of the host computer.
3. Double-click on “RP50Tool.exe” in the “Setup Software” folder which was copied to start Setup Software.

■ IP settings

On the “Setting” tab screen, set the IP addresses of the remote cameras and switcher.

Type	Group	CAMERA No	Type	CAMERA Name	SW Input	MAC Address	IP Address	HTTP Port	CAMERA Select	Alarm
CAMERA	1	C001	NoAssign		NoAssign	00:00:00:00:00:00	0 . 0 . 0 . 0	0		
		C002	NoAssign		NoAssign	00:00:00:00:00:00	0 . 0 . 0 . 0	0		
		C003	NoAssign		NoAssign	00:00:00:00:00:00	0 . 0 . 0 . 0	0		
		C004	NoAssign		NoAssign	00:00:00:00:00:00	0 . 0 . 0 . 0	0		
		C005	NoAssign		NoAssign	00:00:00:00:00:00	0 . 0 . 0 . 0	0		
	2	C006	NoAssign		NoAssign	00:00:00:00:00:00	0 . 0 . 0 . 0	0		
		C007	NoAssign		NoAssign	00:00:00:00:00:00	0 . 0 . 0 . 0	0		
		C008	NoAssign		NoAssign	00:00:00:00:00:00	0 . 0 . 0 . 0	0		
		C009	NoAssign		NoAssign	00:00:00:00:00:00	0 . 0 . 0 . 0	0		
		C010	NoAssign		NoAssign	00:00:00:00:00:00	0 . 0 . 0 . 0	0		
	3	C011	NoAssign		NoAssign	00:00:00:00:00:00	0 . 0 . 0 . 0	0		
		C012	NoAssign		NoAssign	00:00:00:00:00:00	0 . 0 . 0 . 0	0		
		C013	NoAssign		NoAssign	00:00:00:00:00:00	0 . 0 . 0 . 0	0		
		C014	NoAssign		NoAssign	00:00:00:00:00:00	0 . 0 . 0 . 0	0		
		C015	NoAssign		NoAssign	00:00:00:00:00:00	0 . 0 . 0 . 0	0		
SW		NoAssign			00:00:00:00:00:00	0 . 0 . 0 . 0				

Buttons: RENEW, KEEP, REFRESH, ALL CLEAR, SET, CANCEL

Setup Software

● Displaying the “Setting” tab

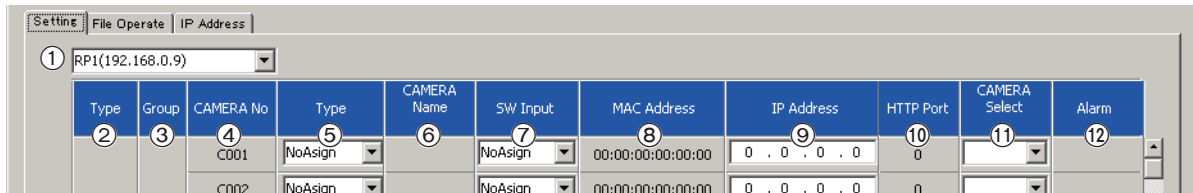

① List box

The IP address of the AW-RP50 connected to the network is displayed here.
The information of the network environment established by the AW-RP50 selected here is displayed on the “Setting” tab.

② Type

The units connected to the selected AW-RP50 are displayed in this column.

CAMERA: Remote camera
SW: Switcher

③ Group

The numbers of the groups of cameras controlled by the selected AW-RP50 are displayed in this column.

④ CAMERA No

The numbers of the cameras controlled by the selected AW-RP50 are displayed in this column.

⑤ Type

The connection methods used for the units connected to the selected AW-RP50 are displayed in this column.

Serial: Serial connection
Network: IP connection
NoAssign: No setting (default setting)

The connection method can be changed manually. Click on the right, and select “Serial,” “Network” or “NoAssign”.
“Serial” can be selected only with Group 1.
After the method has been changed, click the [SET] button to reflect the change.

⑥ CAMERA Name

The names of the cameras set in the remote cameras are displayed in this column.
They are displayed for the remote cameras in the currently selected group.
For remote cameras with a serial connection, they are displayed only when the cameras are selected by the unit.

⑦ SW Input

The input connectors of the switcher are displayed in this column.

The input connector can be changed manually. Click on the right, and select “NoAssign” or an input connector from “INPUT1” to “INPUT5.”
After the connector has been changed, click the [SET] button to reflect the change.

⑧ MAC Address

The MAC addresses of the remote cameras and switcher connected to the selected AW-RP50 are displayed in this column.

⑨ IP Address

The IP addresses of the remote cameras and switcher connected to the selected AW-RP50 are displayed in this column.

The IP addresses can be changed by inputting them directly. After inputting an IP address, click the [SET] button to reflect the change.

⑩ HTTP Port

The numbers of the ports used to connect the selected AW-RP50 are displayed in this column.

⑪ CAMERA Select

The numbers of the cameras to be changed are displayed in this column.

The numbers of the cameras can be changed manually. Click on the right, and select a number from “C001” to “C100.”
After the camera number has been changed, click the [SET] button to reflect the change.

⑫ Alarm

The alarm information of the remote cameras is displayed in this column.
They are displayed for the remote cameras in the currently selected group.
For remote cameras with a serial connection, they are displayed only when the cameras are selected.

Setup Software

● Auto IP setting

■ When IP addresses are to be changed

- 1 Click [RENEW].**
New IP addresses are set in the target remote cameras and switcher.
 - When [CANCEL] is clicked, the original settings are restored.
- 2 Check that the IP addresses of the remote cameras and switcher are displayed correctly, and click [SET].**
The IP addresses which have been set now take effect.

■ When IP addresses are not going to be changed

- 1 Click [KEEP].**
The IP addresses of the target remote cameras and switcher are displayed.
 - When [CANCEL] is clicked, the original settings are restored.
- 2 Check that the IP addresses of the remote cameras and switcher are displayed correctly, and click [SET].**
The displayed IP addresses now take effect.

● Changing the IP addresses

The IP addresses of the remote cameras and switcher can be changed.

- 1 Directly input the IP address of the device concerned into the [IP Address] box.**
- 2 Click [SET].**
The changed IP address now takes effect.

● Changing the camera numbers

The camera numbers set for the remote cameras can be changed.

- 1 Change the camera number for the remote camera concerned in the [CAMERA Select] box.**
- 2 Click [SET].**
The changed camera number now takes effect.

● Registering the camera numbers in the switcher's input connectors

Set the camera numbers to be registered for the input connectors (SDI IN 1 to SDI IN 4, DVI IN) of the switcher.

- 1 Select the camera numbers to be registered in the [SW Input] box.**

SW Input display	Input connector of switcher
Input1	SDI IN 1 to SDI IN 4, DVI IN
Input2	
Input3	
Input4	
Input5	

- 2 Click [SET].**
The registration of the camera numbers into the input connectors of the switcher now takes effect.

● Initializing the IP addresses

The set IP addresses are initialized when [ALL CLEAR] is clicked.

● Acquiring information

When [REFRESH] is clicked, the latest information of the remote cameras and switcher is acquired, and displayed in the "Setting" tab.

Setup Software

■ Saving and loading data

On the “File Operate” tab screen, the files with the network environment settings are saved and loaded.

● Loading the setting files

Load the files with the network environment setting data.
(Filename: *****.r50**)

1 Click [File], and specify the setting file to be loaded.

The name of the selected file is displayed in the text box.

- It is also possible to input the filename directly.

2 Click [Load].

When the file has been loaded, a message is displayed to alert the user to the fact that loading is completed.

● Saving the setting files

Save the files with the network environment setting data.
(Filename: *****.r50**)

1 Click [Save].

The file save screen now appears.

2 Input the filename, and click [Save].

● Saving the log files

Save the log files.
(Filename: **RP50.log**)

1 Click [Save].

The file save screen now appears.

2 Specify the save destination and filename, and click [Save].

📝 Memo 📝

If the same information on the settings for the connections with the remote cameras is shared among a multiple number (up to 5 units) of AW-RP50 remote camera controllers on the same network, perform the steps in “Saving the setting files” (Save) to save the information which has been set in one AW-RP50 unit.

Then return to the “Setting” tab screen, and in the list box select the unit whose setting data is to be reflected.

On the “File Operate” tab screen again, the data can now be reflected by performing the steps in “Loading the setting files” (Load).

Setup Software

■ Referencing the network environment

On the “IP Address” tab, it is possible to select the IP addresses of the other AW-RP50 remote camera controllers which have been connected in the network.

The information of the network environment created by the selected AW-RP50 units can be referenced using the “Setting” tab. Up to five AW-RP50 units can be selected.

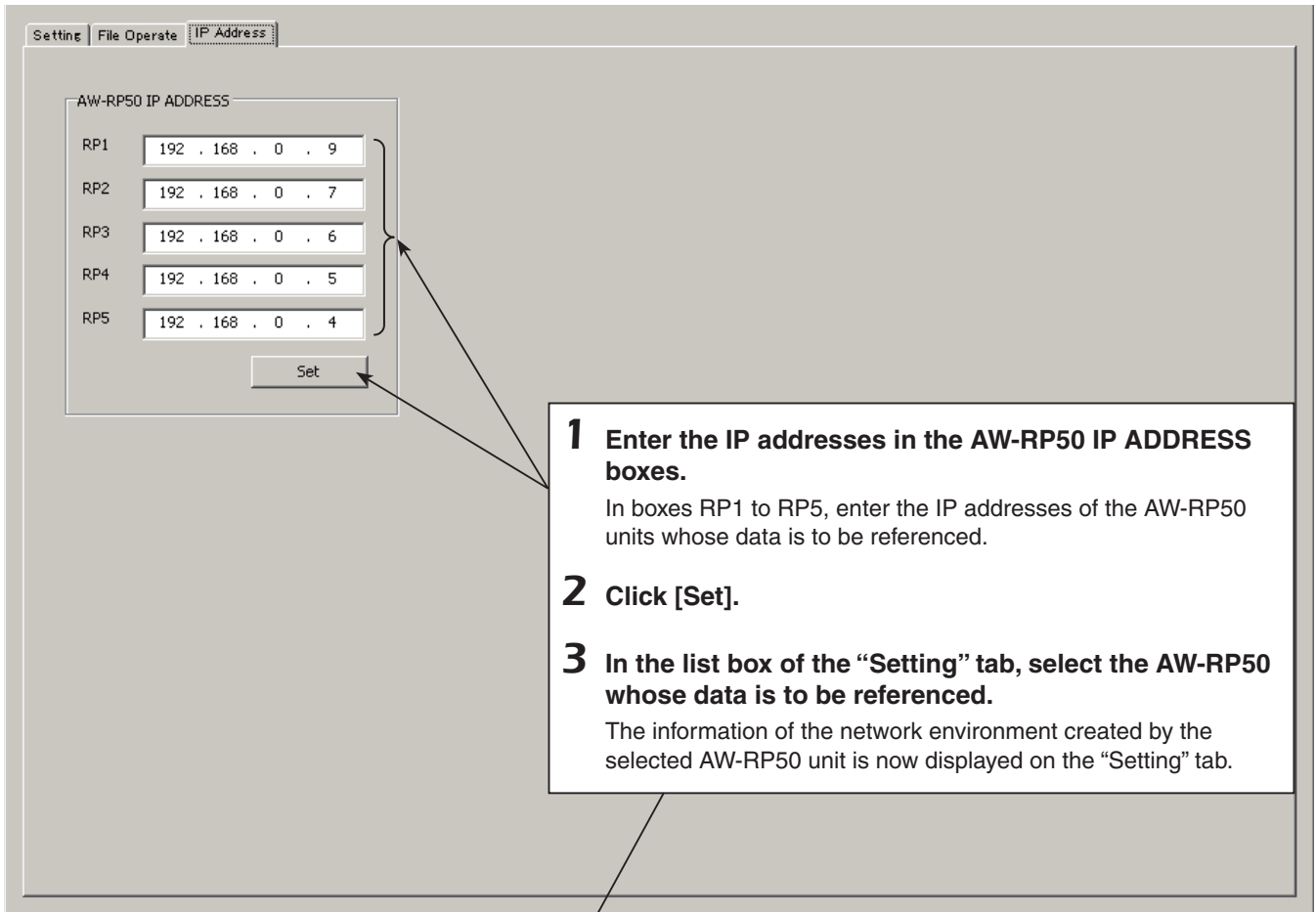

1 Enter the IP addresses in the AW-RP50 IP ADDRESS boxes.
In boxes RP1 to RP5, enter the IP addresses of the AW-RP50 units whose data is to be referenced.

2 Click [Set].

3 In the list box of the “Setting” tab, select the AW-RP50 whose data is to be referenced.
The information of the network environment created by the selected AW-RP50 unit is now displayed on the “Setting” tab.

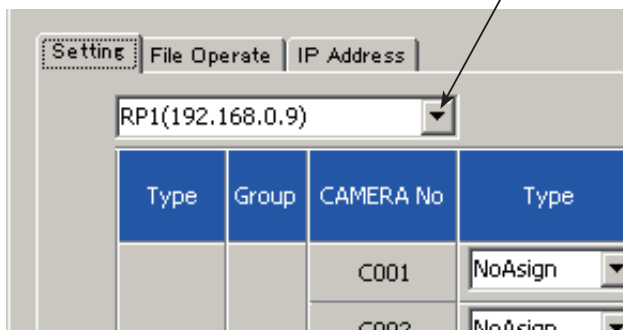

Type	Group	CAMERA No	Type
		C001	NoAssign
		C002	NoAssign

Table of menu items

Button	Menu item	Control device	Initial value	Setting	
1	GAIN/PED	GAIN	AW-HE50		Auto, 0dB, 3dB, 6dB, 9dB, 12dB, 15dB, 18dB
			AW-HE100		AUTO, 0 to 12dB, 15dB, 18dB (0dB to 12dB: 1 step)
			AW-HE870		AUTO, -6dB to 18dB (1 step)
			AW-E860, AW-E750, AW-E650, AW-E350		AUTO, 0 to 30dB, N/Eye L, N/Eye, N/Eye H
			AK-HC1500, AK-HC1800		LOW, MID, HIGH, S.GAIN1, S.GAIN2, S.GAIN3
	PEDESTAL	AW-HE50		-10 to +10	
		AW-HE100		-30 to +30	
		AW-HE870		-150 to +150	
		AW-E860, AW-E750, AW-E650, AW-E350		-150 to +150	
		AK-HC1500, AK-HC1800		-150 to +150	
2	R/BGAIN	RGAIN	AW-HE50		“---”
			AW-HE100		-30 to +30
			AW-HE870		-150 to +150
			AW-E860, AW-E750, AW-E650, AW-E350		-150 to +150
			AK-HC1500, AK-HC1800		-150 to +150
	BGAIN	AW-HE50		“---”	
		AW-HE100		-30 to +30	
		AW-HE870		-150 to +150	
		AW-E860, AW-E750, AW-E650, AW-E350		-150 to +150	
		AK-HC1500, AK-HC1800		-150 to +150	
3	R/BPED	RPED	AW-HE50		“---”
			AW-HE100		“---”
			AW-HE870		-150 to +150
			AW-E860, AW-E750, AW-E650, AW-E350		-150 to +150
			AK-HC1500, AK-HC1800		-100 to +100
	BPED	AW-HE50		“---”	
		AW-HE100		“---”	
		AW-HE870		-150 to +150	
		AW-E860, AW-E750, AW-E650, AW-E350		-150 to +150	
		AK-HC1500, AK-HC1800		-100 to +100	
4	AWB/ABB	AWB SEL	AW-HE50		AWB A, AWB B, ATW
			AW-HE100		AWB A, AWB B, 3200K, 5600K, ATW
			AW-HE870		AWB A, AWB B, 3200K, 5600K, ATW
			AW-E860, AW-E750, AW-E650, AW-E350		AWB A, AWB B, 3200K, 5600K, ATW
			AK-HC1500, AK-HC1800		“---”
	SET			AWB, ABB Note: “ABB” is not displayed on the AW-HE50.	

Table of menu items

Button	Menu item		Control device	Initial value	Setting	
5	SHUTTER	SHUTTER	AW-HE50		Off, Step, Synchro	
			AW-HE100		Off, Step, Synchro	
			AW-HE870		Off, Step, Synchro, ELC	
			AW-E860, AW-E750, AW-E650, AW-E350		Off, Step, Synchro, ELC	
			AK-HC1500, AK-HC1800		Off, Step, Synchro	
	SPEED		AW-HE50		1/100, 1/250, 1/500, 1/1000, 1/2000, 1/4000, 1/10000	
			AW-HE100		1/100, 1/250, 1/500, 1/1000, 1/2000	
			AW-HE870		1/100, 1/250, 1/500, 1/1000, 1/2000, 1/4000, 1/10000	
			AW-E860, AW-E750, AW-E650, AW-E350		1/100, 1/250, 1/500, 1/1000, 1/2000, 1/4000, 1/10000	
			AK-HC1500, AK-HC1800		VIDEO: 1/100, 1/120, 1/250, 1/500, 1/1000, 1/2000 (second) FILME: 180.0, 172.8, 144.0, 120.0, 90.0, 45.0 (degree)	
6	DETAIL	DETAIL			Off, 0n	
		LEVEL	AW-HE50		LOW, HIGH	
			AW-HE100		0 to 14	
			AW-HE870		LOW, HIGH	
			AW-E860, AW-E750, AW-E650, AW-E350		LOW, HIGH	
			AK-HC1500, AK-HC1800		"---"	
7	SCENE/ MODE	SCENE	AW-HE50		F-AUTO, MANU1, MANU2, MANU3	
			AW-HE100		HALOGEN, FLUORE, DAYLIGHT, USER	
			AW-HE870		HALOGEN, FLUORE, OUTDOOR, USER	
			AW-E860, AW-E750, AW-E650, AW-E350		HALOGEN, FLUORE, OUTDOOR, USER	
			AK-HC1500, AK-HC1800		CURRENT, PRESET, USER1, USER2	
		MODE		BAR, CAM		
		8	CAMERA	[1]GROUP	1.GROUP SELECT	1
[2]POWER	1.CAM POWER				GROUP ON	GROUP OFF, GROUP ON, ALL OFF, ALL ON
	2.AUTO ON				Off	Off, 0n
[3]TALLY	1.TALLY OUT				Off	Off, 0n

Table of menu items

Button	Menu item		Control device	Initial value	Setting	
9	SETUP	[1]USER	1.USER1		AWB	SWLINK, BUSCONT, FASIST, CAMSEL, TALLY_IP, CAMINF, AWB, ABB, POWER OFF
			2.USER2		ABB	SWLINK, BUSCONT, FASIST, CAMSEL, TALLY_IP, CAMINF, AWB, ABB, POWER OFF
		[2]SW LINK	1.SWLINK		0n	Off, 0n
	2.BUSCONT			Off	Off, 0n	
	3.BUS			AUX	AUX, PVW, PinP, KEY	
	4.FASIST			Off	Off, 0n	
	5.CAMSEL			Off	Off, 0n	
	6.TALLY_IP			Off	Off, 0n	
	7.P/T LEVER			Self	Self, SW	
	[3]SW DISP	1.CAMINF		0n	Off, 0n	
		2.FORMAT		0n	Off, 0n	
		3.CAMNAME		0n	Off, 0n	
		4.SCENE		0n	Off, 0n	
		5.GAIN		0n	Off, 0n	
		6.SHUTTER		0n	Off, 0n	
		7.IRIS		0n	Off, 0n	
		8.FILTER		0n	Off, 0n	
		9.ALARM		0n	Off, 0n	
	[4]OPERATE	1.PAN DIR		NORMAL	NORMAL, REVERSE	
		2.TILT DIR		NORMAL	NORMAL, REVERSE	
		3.ZOOM DIR		NORMAL	NORMAL, REVERSE	
		4.FOCUS DIR		NORMAL	NORMAL, REVERSE	
		5.SPEED WITH Z	AW-HE50			Off, 0n
			AW-HE100			Off, 1, 2
			AW-PH360, AW-PH400, AW-PH405, AW-PH650			Off, 1, 2
		6.SPEED TARGET		P/T/Z/F	P/T/Z/F, P/T	
	7.FOCUS/IRIS		STANDARD	STANDARD, EXCHANGE		
	8.P/T CURV		1	1 to 5		
	[5]PRESET	1.DIAG SPEED	AW-HE50		1 to 30	
			AW-HE100	30	1 to 30	
			AW-PH360, AW-PH400, AW-PH405, AW-PH650	30	1 to 30	
		2.SCOPE	AW-HE50	30	MODE A, MODE B, MODE C	
			AW-HE100	30	“---”	
AW-PH360, AW-PH400, AW-PH405, AW-PH650			“---”			
3.HOME POSITION			SET			

Table of menu items

Button	Menu item	Control device	Initial value	Setting		
9 SETUP	[6]FUNCTION	1.ND FILTER	AW-HE50	“---”		
			AW-HE100	“---”		
			AW-HE870	Off, On		
			AW-E860, AW-E750, AW-E650, AW-E350	Off, On		
			AK-HC1500, AK-HC1800	Clear, 1/4, 1/16, 1/64		
		2.OPTION	AW-HE50	Off, On		
			AW-HE100	Off, On		
			AW-PH360, AW-PH400, AW-PH405	Off, On		
			AW-PH650	Off, On		
		3.DEFROSTER	AW-HE50	“---”		
			AW-HE100	“---”		
			AW-PH360, AW-PH400, AW-PH405	Off, On		
			AW-PH650	Off, On		
		4.WIPER	AW-HE50	“---”		
			AW-HE100	“---”		
			AW-PH360, AW-PH400, AW-PH405	Off, On		
			AW-PH650	Off, On		
		5.HEATER/FAN	AW-HE50	“---”		
			AW-HE100	“---”		
			AW-PH360, AW-PH400, AW-PH405	Off, On		
			AW-PH650	Off, On		
		6.LAMP	AW-HE50	“---”		
			AW-HE100	“---”		
			AW-PH360, AW-PH400, AW-PH405	Off, On		
	AW-PH650		Off, On			
	[7]PTZ ADJ	1.Z MIN SPEED		Off	Off, 1 to 8	
		2.LIMIT UP	AW-HE50			Off, On
			AW-HE100			EXEC
			AW-PH360, AW-PH400, AW-PH405, AW-PH650			EXEC
		3.LIMIT DOWN	AW-HE50			Off, On
			AW-HE100			EXEC
			AW-PH360, AW-PH400, AW-PH405, AW-PH650			EXEC
		4.LIMIT LEFT	AW-HE50			Off, On
			AW-HE100			EXEC
			AW-PH360, AW-PH400, AW-PH405, AW-PH650			EXEC
		5.LIMIT RIGHT	AW-HE50			Off, On
	AW-HE100				EXEC	
	AW-PH360, AW-PH400, AW-PH405, AW-PH650				EXEC	
	[8]GPI	1.PRESET CTL1		CAM1 : PRE1	CAM1 : PRE1 to CAM100 : PRE100, ALL : PRE1 to ALL : PRE100	
		2.PRESET CTL2		CAM2 : PRE1		
3.PRESET CTL3			CAM3 : PRE1			
[9]LCD BL	1.BACKLIGHT		On	Off, On		
[10]MENU CTL	1.MENU CONTROL		ENABLE	ENABLE, DISABLE		

Table of menu items

Button	Menu item	Control device	Initial value	Setting	
10 SYSTEM	[1]CAMERA CTL	1.CAM1 to 100.CAM100	NoAssign	Serial, Network, NoAssign	
	[2]CAM ASSIGN	1.CAM1 to 100.CAM100	192.168.000.010		
	[3]SW CTL	1.SW	NoAssign	Network, NoAssign	
	[4]SW ASSIGN	1.INPUT1		CAM1	NoAssign, CAM1 to 100
		2.INPUT2		CAM2	
		3.INPUT3		CAM3	
		4.INPUT4		CAM4	
		5.INPUT5		CAM5	
	[5]AUTO SET IP	1.AUTO SETUP		RENEW IP ADR	RENEW IP ADR, KEEP IP ADR, ALL CLEAR
	[6]NETWORK	1.IP ADDRESS		192.168.000.009	
		2.SUBNETMASK		255.255.255.000	
		3.GATEWAY		192.168.000.001	
4.MAC ADDRESS				Display only	
[7]CAM IP ADR	1.IP:CAM1 to 100.IP:CAM100		192.168.000.010 to 192.168.000.109		
[8]CAM PORT	1.PORT:CAM1 to 100.PORT:100		80	1 to 65535	
[9]SW IP ADR	1.IP:SW		192.168.000.008		
[10]ALARM	1.POWER			ALARM, No ALARM	
	2.CAM*** (Note)			FAN ALM, P/T ALM, FAN ALM+P/T ALM, No ALARM	
	3.CAM*** (Note)				
	4.CAM*** (Note)				
	5.CAM*** (Note)				
	6.CAM*** (Note)				
[11]INITIALIZE	1.INITIALIZE			ALL, SETUP	
[12]VERSION	1.SYSTEM VER			V.***.**	
	2.PROGRAM VER			V.****	
	3.FPGA VER			V.****	

Note: "***" is the number of the camera in the selected group of cameras.

Panasonic®

Panasonic Solutions Company

3 Panasonic Way, Secaucus, NJ 07094 Tel: 877-803-8492
www.panasonic.com/broadcast e-mail: MediaProServices.PSC@us.panasonic.com

Panasonic Canada Inc.

5770 Ambler Drive, Mississauga, Ontario L4W 2T3 Tel: 905-624-5010

Panasonic de Mexico S.A. de C.V.

Casa Matriz: Felix Cuevas No. 6 Pisos 2 y 3 Col. Tlacoquemecatl Del Valle Del Benito Juárez México, D.F., C.P.03200
Tel: 55-5488-1000 Fax: 55-5575-6763

Panasonic Latin America, S.A.

Avenida Simon Bolivar, Edificio Panasonic P.O.Box 0816-03164 Panama, Republic of Panama Tel: +507-229-2955 Fax: 507-229-5352

Panasonic do Brasil Ltda.

Rua Cubatão, 320 - 8 andar - Paraíso CEP: 04013-001 São Paulo - SP Tel: (11) 3889-4000 Fax: (11) 3889-4107

© Panasonic System Networks Co., Ltd. 2010

Printed in Japan
F0610Y1070 

**Strengthening Parliamentary Control
in Zambia,
LOT 1- New TV-Studio**

Extra Bill of Quantity
(to be completed by the bidder)

Item	Manufact.	Description	Type	Comment	Qty. pcs.	Retail Price per unit Euro	Retail Price main item tot. Euro
1		Equipment					
1.5		Control Room					
1.5.40	Lake People or equivalent	Headphone amp, 2 channel analogue audio sym.	PHONE-AMP F388 S	new	3	- €	- €
1.5.41	Sennheiser or equivalent	stereo headphones impedance: 60 ohms frequency response: 30Hz-16KHz (-3dB)	HD 25-SP II	additional	3	- €	- €
1.5.42	Samsung or equivalent	Monitor 24" 1920 x 1080 Full HD VGA, HDMI	S22E390H	additional	1	- €	- €
1.5.43	Ross or equivalent	1x8 reference distribution	VEA-8707A-R2A	new	1	- €	- €
1.5.44	Ross or equivalent	HD / SD SDI Frame Synch w/ 8x Analog Audio Input	SFS-8622A-IC- R2C	new	4	- €	- €
1.5.45	Ross or equivalent	HD / SD SDI Frame Synchronizer	SFS-8622A-A- R2A	new	6	- €	- €
1.5.46	Ross or equivalent	Frame for openGear Cards 20 openGear card slots, 1 controller slot, and 1 reference slot Includes basic network controller, reference card, cooling system and one power supply	OG3-FR-C	new	1	- €	- €
1.5.47	Ross or equivalent	Redundant power supply	PS-OG3	new	1	- €	- €
1.5.48	Dell or equivalent	PC Keyboard with standard layout, USB	KB212	new	2	- €	- €
1.5.49	Dell or equivalent	Optical mouse, 3 button, USB	MS111	new	2	- €	- €
1.5.50	Kramer or equivalent	1x8 reference distribution, size - compact desktop	VM-80VN	new	1	- €	- €
1.5.51	Blackmagic or equivalent	HD-SDI distribution amplifier, compact design, connects a single source to 8 re clocked outputs	Mini Converter SDI Distribution	new	2	- €	- €

Note: Requirements, see
Technical Tender Compliance Tables

**Strengthening Parliamentary Control
in Zambia,
LOT 1- New TV-Studio**

Extra Bill of Quantity
(to be completed by the bidder)

Item	Manufact.	Description	Type	Comment	Qty. pcs.	Retail Price	Retail Price
						per unit	main item tot.
						Euro	Euro
1.5.52	Kramer or equivalent	Composite Video Optical Transmitter Bandwidth - 55MHz (-3dB) Level (Gain) and EQ (Peaking) Controls	611T	new	1	- €	- €
1.5.53	Kramer or equivalent	Composite Video Optical Receiver Bandwidth - 55MHz (-3dB) Level (Gain) and EQ (Peaking) Controls	611R	new	1	- €	- €
1.5.54	G&D or equivalent	KVM extender, transmission of DVI signals via CAT, up to 140 m transmission length, receiver	DVI-Vision-CAT- AR-CON	new	1	- €	- €
1.5.55	G&D or equivalent	KVM extender, transmission of DVI signals via CAT, up to 140 m transmission length, transmitter	DVI-Vision-CAT- AR-CPU	new	1	- €	- €
1.5.56	Canare or equivalent	Video jackfield, 2x32, self-normalling, mid-size, 'mini-WEC0' style	32MD-ST	new	1	- €	- €
1.5.57	Canare or equivalent	Video patchcord 300 mm	MVPC003	new	10	- €	- €
1.5.58	n.n.	Wallbox OB Vehicle (2x Video, Power socket, 1x network), weather proof		new	1	- €	- €
1.5.59	Blackmagic or equivalent	HD-SDI Audio deembedder, 4ch. Analogue	SDI-Audio	new	3	- €	- €
1.5.60	Ross or equivalent	High quality downconverter with 4 reclocked outputs and 4 configurable SD/analog outputs	HDC-8223-R2	additional	1	- €	- €
1.5.61	Decimator or equivalent	HD-SDI-HDMI converter	Decimator 2	additional	1	- €	- €
1.5.62	Cisco or equivalent	28-Port GB-Switch 24x GB-LAN, mini-GBIC Managed, VLAN, PoE+ 2x Gigabit Ethernet Mini GBIC fiber transceiver	SG300-28MP MGBLH1	Ammend ed replacem ent for position:1 .5.1	1	- €	- €

**Strengthening Parliamentary Control
in Zambia,
LOT 1- New TV-Studio**

Extra Bill of Quantity
(to be completed by the bidder)

Item	Manufact.	Description	Type	Comment	Qty. pcs.	Retail Price	Retail Price
						per unit	main item tot.
						Euro	Euro
1.5.63	Broaman or equivalent	Fiber transmitter 1x SDI(SD/HD/3G) In reclocked, redundant fibre transmitter Channel status LEDs Built-in dual power supply with automatic switchover 1RU design		Ammend ed replacem ent for position:1 .6.3	1	- €	- €
1.5.64	Broaman or equivalent	Fiber receiver 1x SDI(SD/HD/3G) Out, redundant fibre receiver with automatic change over unit Channel status LEDs Built-in dual power supply with automatic switchover 1RU design		Ammend ed replacem ent for position:1 .6.3	1	- €	- €
1.5.65	n.n.	Rack cabinet 19 inch, with Fan, Filter mat 47RU, 1000mm depth, with glass front door	see Att. 10	Ammend ed replacem ent for position:1 .5.29	1		- €
1.5.66	n.n.	Rack cabinet 19 inch 16RU, 600mm depth, with glass front door	see Att. 10	new	1	- €	- €
1.5.67	APC or equivalent	Uninterruptible power supply 5000 VA, runtime 5 minutes full load, 3RU rackmountable power conditioner	SUA5000RMXLI 3U	Ammend ed replacem ent for position:1 .5.30	1	- €	- €
		Totalsum net			1		- €

Strengthening Parliamentary Control
in Zambia,
LOT 1- New TV-Studio

Extra Bill of Quantity
(to be completed by the bidder)

Item	Manufact.	Description	Type	Comment	Qty. pcs.	Retail Price per unit Euro	Retail Price main item tot. Euro
		Freight, CIP (Carriage Insurance Paid) to NAZ, Lusaka	INCOTERMS		1	- €	- €
		Totalsum net, incl. Freight and Insurance			1		<u>- €</u>